

CM0711

Instruction Book

Publ. no HY33-4201-IB/UK

Edition 6/2021

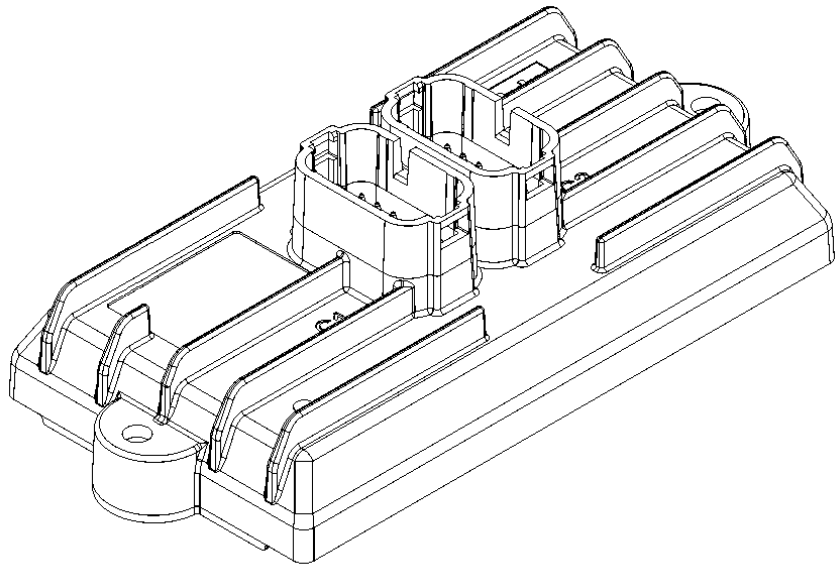

Parker Hannifin Manufacturing Finland Oy
Mobile Hydraulic Systems Division Europe
Electronic Controls Business Unit
Lepistökatu 10
FI-30100 Forssa, Finland
Office +358 20 753 2500

<http://www.parker.com/ecd>

Copyright 2012 - 2021 © Parker Hannifin Corporation. All rights reserved. No part of this work may be reproduced, published, or distributed in any form or by any means (electronically, mechanically, photocopying, recording, or otherwise), or stored in a database retrieval system, without the prior written permission of Parker Hannifin in each instance.



WARNING!

FAILURE OR IMPROPER SELECTION OR IMPROPER USE OF THE PRODUCTS AND/OR SYSTEMS DESCRIBED HEREIN OR RELATED ITEMS CAN CAUSE DEATH, PERSONAL INJURY AND PROPERTY DAMAGE.

This document and other information from Parker Hannifin Corporation, its subsidiaries and authorized distributors provide product and/or system options for further investigation by users having technical expertise. It is important that you analyze all aspects of your application and review the information concerning the product or system in the current product catalog. Due to the variety of operating conditions and applications for these products or systems, the user, through its own analysis and testing, is solely responsible for making the final selection of the products and systems and assuring that all performance, safety and warning requirements of the application are met.

The products described herein, including without limitation, product features, specifications, designs, availability and pricing, are subject to change by Parker Hannifin Corporation and its subsidiaries at any time without notice.

Contents

1. Introduction	6
1.1. Safety Symbols	6
2. Precautions	7
2.1. General Safety Regulations	7
2.1.1. Construction Regulations	8
2.1.2. Safety During Installation	8
2.1.3. Safety During Start-up	8
2.1.4. Safety During Maintenance and Fault Diagnosis	8
3. How to Use this Manual	9
3.1. Diagram Conventions	9
4. Product Description	11
4.1. General	11
4.2. I/O Overview	12
5. Quick Start	13
5.1. Gathering Required Materials	13
5.2. Installing the Required Software Tools	13
5.2.1. Installing the Data Link Adaptor (DLA) Driver Software	14
5.3. Connecting to a Development System	14
5.3.1. Powering Up the Development System	16
5.4. Creating and Downloading Software Applications	17
6. Inputs	18
6.1. Analog Inputs	18
6.1.1. Analog Input Type 1 (Resistive Sensors)	18
6.1.2. Analog Inputs Type 2 (General Purpose)	20
6.1.3. Analog Input Installation Connections	23
6.2. Frequency Inputs	24
6.2.1. Frequency Input Capabilities	24
6.2.2. Frequency Input Configuration	25
6.2.3. Frequency Input Software Considerations	25
6.2.4. Frequency Input Installation Connections	25
7. Outputs	27
7.1. High Side Outputs	27
7.1.1. High Side Output Capabilities	27
7.1.2. High Side Output Configuration	30
7.1.3. High Side Output Software Considerations	31
7.1.4. High Side Output Installation Connections	31
7.1.5. High Side Output Diagnostics and Fault Protection	32
7.2. Low Side Outputs	33
7.2.1. Low Side Output Capabilities	33
7.2.2. Low Side Outputs Configuration	35
7.2.3. Low Side Output Software Considerations	35
7.2.4. Low Side Outputs Installation Connections	35
7.2.5. Low Side Outputs Diagnostics and Fault Protection	36
8. Power	37
8.1. Module Power	37

8.1.1.	Module Power Capabilities	37
8.1.2.	Ignition Input and Power Input Switch	38
8.1.3.	Module Power Installation Connections	38
8.2.	Sensor Power	39
8.2.1.	Sensor Power Capabilities	40
8.2.2.	Sensor Power Installation Connections	40
8.2.3.	Sensor Power Diagnostics and Fault Protection	40
9.	Microcontroller, Memory and Internal Diagnostics	41
9.1.	Analog to Digital (A/D) Converter	41
9.2.	SRAM	41
9.3.	Flash Memory	42
9.4.	Reset Sources	43
9.5.	Internal Diagnostics	43
10.	Communication	45
10.1.	Controller Area Network (CAN)	45
10.1.1.	J1939 CAN Capabilities	45
10.1.2.	J1939 CAN Configuration	45
10.1.3.	J1939 CAN Installation Connections	45
10.2.	Module ID	47
10.2.1.	Module ID Capabilities	47
10.2.2.	Module ID Configuration	48
10.2.3.	Module ID Installation Connections	48
10.2.4.	Module ID Diagnostics and Fault Protection	48
10.2.5.	ID-Tag Part Numbers	49
11.	Connectors	50
11.1.	General	50
11.2.	Mating Connector Part Numbers	51
11.3.	Connector Pin-outs	52
12.	Installing into a Vehicle	54
12.1.	Mechanical Guidelines	54
12.1.1.	Dimensions	54
12.1.2.	Selecting a Mounting Location	55
12.1.3.	Mounting to a Vehicle	56
12.2.	Electrical Guidelines	57
12.2.1.	Designing the Vehicle Harness	57
12.2.2.	Connecting the Vehicle Harness	57
13.	Application Examples	58
13.1.	Implementing Safety Interlocks	58
13.2.	Controlling Indicator Lights	59
13.3.	Controlling a Proportional Valve	61
13.4.	Controlling Motor Speed	62
13.5.	Using one Analog Input as Two Digital Inputs	62
13.6.	Controlling a Linear Actuator	63
13.7.	Connecting Common Sensors	65
13.7.1.	Open Collector Sensors	65
13.7.2.	Switch Sensors	66
13.7.3.	Voltage Sensors	66
13.7.4.	Potentiometer (Ratiometric) Sensors	67
14.	Start-Up	69
14.1.	Start-Up Procedures	69

14.1.1. Starting the Control System	69
14.1.2. Prepare for System Start	69
14.1.3. Start the System	70
15. Summary of Tests	71
15.1. Design Verification Tests	71
16. Glossary of Terms	73
17. Index	79

1. Introduction

These instructions are meant as a reference tool for the vehicle manufacturer's design, production, and service personnel.

The user of this manual should have basic knowledge in the handling of electronic equipment.

1.1. Safety Symbols

Sections regarding safety, marked with a symbol in the left margin, must be read and understood by everyone using the system, carrying out service work or making changes to hardware and software.

The different safety levels used in this manual are defined below.



WARNING

Sections marked with a warning symbol in the left margin, indicate that a hazardous situation exists. If precautions are not taken, this could result in death, serious injury or major property damage.



CAUTION

Sections marked with a caution symbol in the left margin, indicate that a potentially hazardous situation exists. If precautions are not taken, this could result in minor injury or property damage.



NOTICE

Sections marked with a notice symbol in the left margin, indicate there is important information about the product. Ignoring this could result in damage to the product.

Contact the manufacturer if there is anything you are not sure about or if you have any questions regarding the product and its handling or maintenance.

The term "manufacturer" refers to Parker Hannifin Corporation

2. Precautions

2.1. General Safety Regulations

Work on the hydraulics control electronics may only be carried out by trained personnel who are well-acquainted with the control system, the machine and its safety regulations.



WARNING

Mounting, modification, repair and maintenance must be carried out in accordance with the manufacturer's regulations. The manufacturer has no responsibility for any accidents caused by incorrectly mounted or incorrectly maintained equipment. The manufacturer does not assume any responsibility for the system being incorrectly applied, or the system being programmed in a manner that jeopardizes safety.



WARNING

Damaged product may not be used. If the control system shows error functions or if electronic modules, cabling or connectors are damaged, the system shall not be used.



WARNING

Electronic control systems in an inappropriate installation and in combination with strong electromagnetic interference fields can, in extreme cases, cause an unintentional change of speed of the output function.



NOTICE

As much as possible of the welding work on the chassis should be done before the installation of the system. If welding has to be done afterwards, the electrical connections on the system must be disconnected from other equipment. The negative cable must always be disconnected from the battery before disconnecting the positive cable. The ground wire of the welder shall be positioned as close as possible to the place of the welding. The cables on the welding unit shall never be placed near the electrical wires of the control system.

2.1.1. Construction Regulations



CAUTION

The vehicle must be equipped with an emergency stop which disconnects the supply voltage to the control system's electrical units. The emergency stop must be easily accessible to the operator. The machine must be built if possible, so that the supply voltage to the control system's electrical units is disconnected when the operator leaves the operator's station.

2.1.2. Safety During Installation



CAUTION

Incorrectly positioned or mounted cabling can be influenced by radio signals which can interfere with the functions of the system.

2.1.3. Safety During Start-up



WARNING

The machine's engine must not be started before the control system is mounted and its electrical functions have been verified.

Ensure that no one is in front, behind or nearby the machine when first starting up the machine.

Follow the instructions for function control in the Start-up section.

2.1.4. Safety During Maintenance and Fault Diagnosis



CAUTION

Ensure that the following requirements are fulfilled before any work is carried out on the hydraulics control electronics.









- The machine cannot start moving.
 - Functions are positioned safely.
 - The machine is turned off.
 - The hydraulic system is relieved from any pressure.
 - Supply voltage to the control electronics is disconnected.
-





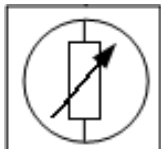

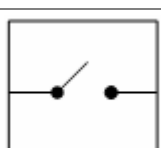
3. How to Use this Manual

This manual describes the hardware components of the CM0711, but does not explain how to write or configure the software. For more information about software, refer to *CM0711 SDK Software Manual*, or contact your Parker Account Representative.

3.1. Diagram Conventions

There are many connection diagrams found throughout this manual. The following table provides meanings for the different symbols used in those diagrams:

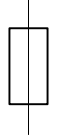
Symbol	Meaning
	General input
	General output
	Frequency input
	Analog input
	Frequency sensor
	Resistive sensor
	General sensor
	Application switch
	Load

Symbol	Meaning
	Resistor
	Pull-down resistor
	Pull-up resistor
	Diode
	Battery
	Fuse
	Ground
	Chassis ground

4. Product Description

4.1. General

The Parker Controller Module 0711 (CM0711) is a general purpose input/output unit that is intended for use in vehicles either on their own or with other CAN /J1939 based equipment.



Figure 1: CM0711

The CM0711 main focus is on high-end output control with closed loop current control but it also is capable of measuring analog and digital input signals. The CM0711 can control proportional valves using current mode (current closed-loop) or PWM mode (voltage open-loop) signals.

This product is designed for the outdoor environment and comes with an IP69K protection for applications where high-pressure water and steam jet cleaning is used.

The CM0711 is mainly intended for applications such as powertrain control (e.g. power shift transmissions), implementing single features on a vehicle (like auxiliary hydraulics control), or to act as an additional controller in systems, where existing main controller do not provide enough I/O for the system.

4.2. I/O Overview

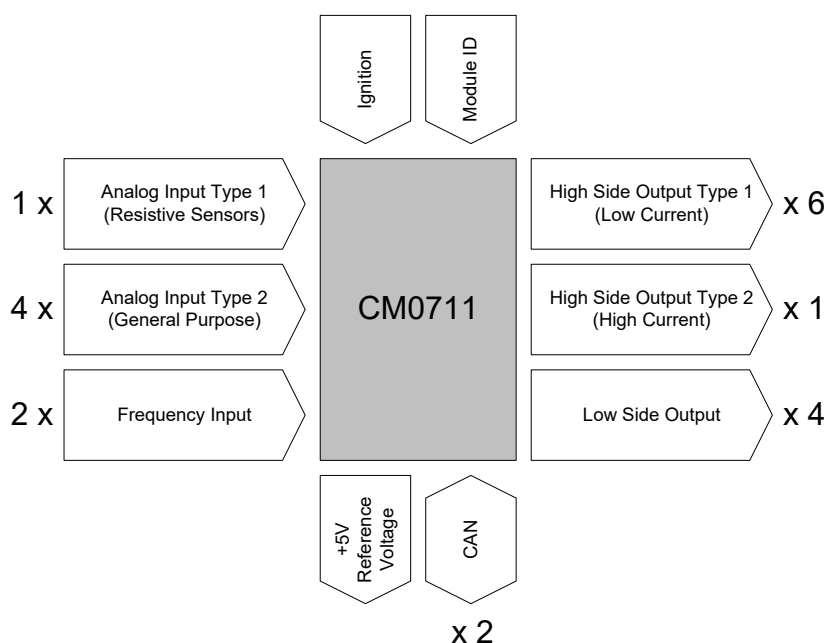

Figure 2: CM0711 inputs and outputs

The CM0711 has 5 analog inputs. One of the analog inputs is designed for resistive sensors and it is amplified with software selectable gain. The other four analog inputs have a fixed input voltage range or by utilizing software selectable pull-down options they can also be used as current inputs. The CM0711 provides a reference voltage output which can be used to supply sensors in the system. The two frequency inputs of this product can alternatively be used as one directional frequency (quadrature) input or their diagnostic inputs can be used as general purpose analog inputs.¹ All seven inputs are also capable of acting as digital inputs.

The CM0711 has 4 digital low side outputs with current sensing and 7 digital high side outputs. Low side outputs and six of the high side outputs can drive resistive and inductive loads up to 2 A. The seventh high side output can drive loads up to 5 A. Pulse width modulation (PWM) is possible on all low side and high side outputs.

High side and low side outputs can be coupled together to create half bridge and H bridge outputs.² For current feedback control applications, the low side outputs can be used as current return paths providing the current sensing.

The CM0711 communicates with other modules through CAN (Controller Area Network) interfaces.

In addition to actuating inputs mentioned above, the CM0711 has control inputs with dedicated purposes: ignition input for module power control and module ID input for identifying several modules in the system.

¹ Refer to separate release schedule for software support to certain functions.

² Refer to separate release schedule for software support to certain functions.

5. Quick Start

This section provides step-by-step instructions for how to connect the CM0711 to a development system, install the required software tools, and download application software.

The following is a high-level overview of the steps involved with this section:

1. Gather the **required materials**.
2. Install the required **software tools** provided by Parker.
3. Connect the CM0711 to a **development system** (desktop) and power it up.
4. Download **application software**.

5.1. Gathering Required Materials

The following materials are required for the procedures in this section:

- A **CM0711**
- A **personal computer** (PC)
- A **controller I/O board**
- A **controller I/O harness** (connects the CM0711 to the controller I/O board)
- An **evaluation kit power harness** (connects the controller I/O board to the power supply)
- A **Data Link Adapter (DLA) kit** (comes with cables needed for connecting the DLA to your PC and to the rest of the system, as well as driver software that must be installed on your PC)
- A **desktop power supply** compatible with the CM0711 and controller I/O board loads (a 12 VDC, 3 A fixed voltage supply is generally suitable, unless driving more significant loads)
- **Software tools** and files required for programming and downloading software for the CM0711.

INFORMATION

With the exception of the PC and desktop power supply, all materials and software are available from Parker. Please consult your Parker Account Representative for specific details and pricing information.

5.2. Installing the Required Software Tools

Before you start using the CM0711, you must install the software tools onto your PC.

The CM0711 requires the following software tools:

- **Data Link Adaptor (DLA) drivers:** The DLA acts as the interface between the PC and the CM0711. Before using the DLA, you must install the DLA drivers.

- **Parker Software Downloading Tools:** Parker provides the software tool to create and download software for the CM0711. Contact your Parker Account Representative to obtain the software downloading tool.

5.2.1. Installing the Data Link Adaptor (DLA) Driver Software

A Data Link Adaptor (DLA) is needed when connecting the CM0711 in a development system.

The Parker DLA requires DLA driver software that you must install on your PC.

INFORMATION

Parker provides the latest DLA software releases through its web site. Please contact your Parker Account Representative for details on how to download the latest DLA driver software.

To install the Parker DLA driver software

1. **Download** the software, run the extracted file and follow the *Install Wizard*.
Once the DLA driver software is installed,
2. Plug the **USB DLA** into a USB port on your PC.
The *Found New Hardware* screen opens.
3. Select **Install the software automatically (Recommended)**, and then click **Next**.
Once the software is finished being installed,
4. Click **Finish**.
The USB DLA is now recognized and ready to be used.

5.3. Connecting to a Development System

It is a good idea to connect the CM0711 to a development system (PC, Controller I/O Board, power source, and DLA) to verify your application. The development system is an ideal environment for creating and downloading software applications.

The following is an overall block diagram of how to connect the CM0711 in a development system:

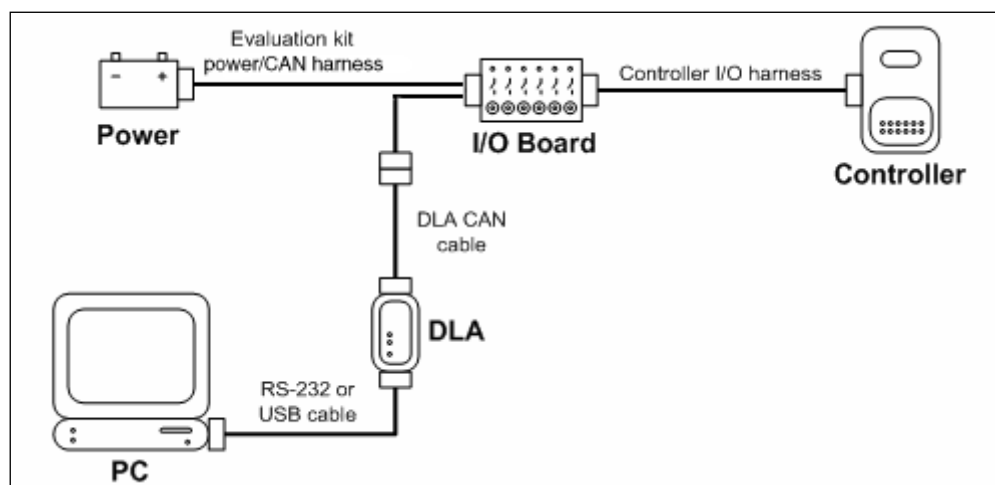

Figure 3: Development system connection

To connect the CM0711 in a development system, do the following:



NOTICE

Before connecting anything in the development system, ensure the power supply is set to a voltage that is less than 28 VDC.



NOTICE

You must install the DLA drivers before connecting the DLA to the PC.

1. Connect the **Controller I/O harness** to the CM0711 connectors.
2. Connect the **Controller I/O harness** to the controller I/O board connectors.
3. Connect the **evaluation kit power/CAN harness** to the controller I/O board's JP3 connector.
4. Do *not* connect the **power wire** (RED) from the evaluation kit power/CAN harness to the power supply (+) terminal at this time.
5. Connect the **ground wire** (BLACK) from the evaluation kit power/CAN harness to the power supply (-) terminal.
6. Connect the **CAN connector** from the evaluation kit power/CAN harness to the corresponding mating connector and harness on the DLA.
7. Connect the **DLA** to a personal computer via the RS-232 port or the USB port (determined by which version of DLA you are using).

5.3.1. Powering Up the Development System

Once the CM0711 is set up in a development system, you need to power it up.



NOTICE

If the controller I/O harness is modified or other than dedicated CM711 harness provided by Parker is used, the following instructions may not apply.

To power up the CM0711, do the following:

1. Ensure the controller I/O board digital DIP switches are properly configured. With the standard controller I/O harness for the CM0711 CAN_LO / CAN_HI switch shall be on right position (on), as there is no termination resistor for CAN1 in the harness. The other DIP switches are not in use with the standard CM0711 harness. Refer to the *Controller I/O Board Reference Manual* for further details.

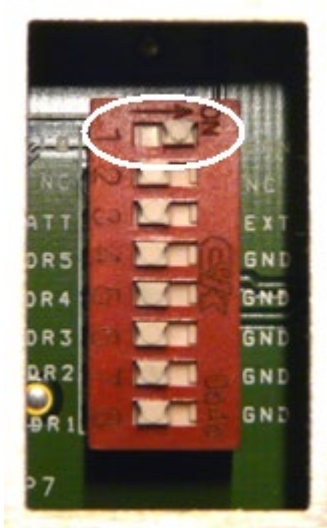

Figure 4: Recommended controller I/O board DIP switch configuration for the CM0711

2. Ensure the controller I/O board jumpers are properly configured. With the standard controller I/O harness for the CM0711 the jumper connecting V_SENSOR to VBATT shall be removed, as the SENSOR_SUPPLY from the CM0711 is connected to V_SENSOR. The other jumpers can be configured depending on the desired simulation functionality. Refer to the *Controller I/O Board Reference Manual* for further details.



Figure 5: Recommended controller I/O board jumper configuration for the CM0711

3. Ensure all controller I/O board digital inputs are properly configured. Refer to the *Controller I/O Board Reference Manual* for further details.
4. Ensure the **power wire** (RED) on the controller I/O board is **not** connected to the power supply (refer to the *Controller I/O Board Reference Manual* for details).
5. Turn the power supply **on**.
6. If using a variable power supply, set the voltage to a value **between 10 - 28 VDC**.
7. Turn the power supply **off**.
8. Connect the **power wire** (RED) on the connector I/O board to the power supply.
9. Turn the power supply **on**.
10. Switch on INPUT_1 on controller I/O board to power up the CM0711. In the standard controller I/O harness for the CM0711 the IGNITION_INPUT is connected to INPUT_1.

5.4. Creating and Downloading Software Applications

Software applications can be created and downloaded to the CM0711.

The software applications for the CM0711 can be created with the tools provided by Parker.

Consult your Parker Account Representative for information about your software programming options.

6. Inputs

The CM0711 has three types of inputs:

- Analog input type 1 (resistive sensors)
- Analog inputs type 2 (general purpose)
- Frequency inputs

6.1. Analog Inputs

6.1.1. Analog Input Type 1 (Resistive Sensors)

The CM0711 has one type 1 analog input:

- ANALOG_INPUT1

6.1.1.1. Analog Input Type 1 (Resistive Sensors) Capabilities

This type of input can be used to measure resistive values such as fuel level and resistive temperature sensors or voltage values. The input is amplified and the gain is software configurable. Pull-up and pull-down resistor configuration is software selectable. The input can also be configured to act as a digital input.

The following table provides specifications for the CM0711's analog input type 1:

Table 1: Analog Input Type 1 Specifications

Item	Min	Nom	Max	Units
Input voltage range				
18,7 gain	0.005		0.170	V
Unity gain	0.1		3.2	V
1/2 attenuation	0.2		6.4	V
1/11 attenuation	1		35	V
Pull-up resistance		6950		Ω
Pull-up voltage	4.85	5.0	5.15	V
Pull-down resistance		2200		Ω
Minimum -ve going threshold	Software configurable			
Maximum +ve going threshold	Software configurable			
Cutoff frequency				
18,7 gain		339		Hz
Unity gain		339		Hz
1/2 attenuation		677		Hz
1/11 attenuation		3 725		Hz
Wetting current				
24 V pulled down		10.9		mA
12 V pulled down		5.5		mA

Item	Min	Nom	Max	Units
Resolution			10	bits
18,7 gain		0.18		mV
Unity gain		3.3		mV
1/2 attenuation		6.6		mV
1/11 attenuation		36		mV
Accuracy			3	%
ADC reference voltage	3.250	3.3	3.350	V
Over-voltage tolerance	36			V
Input pin capacitance		10		nF

INFORMATION

To prevent aliasing, the sampling rate must be greater than twice the frequency of the filter or the input signal, according to the Nyquist criterion.

6.1.1.2. Analog Input Type 1 (Resistive Sensors) Configuration

Software configurable gain:

- 18,7 gain: for resistance measurements in range 10 to 240 Ω and voltage measurements in range 5 to 170 mV
- Unity gain: for resistance measurements in range 200 to 12000 Ω and voltage measurements in range 0,1 to 3,2 V
- 1/2 attenuation: for resistance measurements in range 400 to 30000 Ω and voltage measurements in range 0,2 to 6,4 V
Note: Measured voltage is not directly proportional to the resistance at the input because voltage divider resistors are in parallel with the resistance to be measured.
- 1/11 attenuation: for voltage measurements in range 1 to 35 V

Software selectable pull-up and pull-down resistor configuration:

- 6950 Ω pull-up to 5 V
- 2200 Ω pull-down to ground



WARNING

If more than one of the inputs with pull-up to 5 V configuration have simultaneous over-voltage fault, the pull-up voltage may rise higher than 5 V. This may result in faulty results from other inputs with pull-up to 5 V. The application software must be written to determine how the CM0711 will behave when the 5 V pull-up voltage is out of range.

Digital input configuration:

- Software configurable threshold voltages in range 1 to 35 V

The following diagram shows the configuration for type 1 analog input:

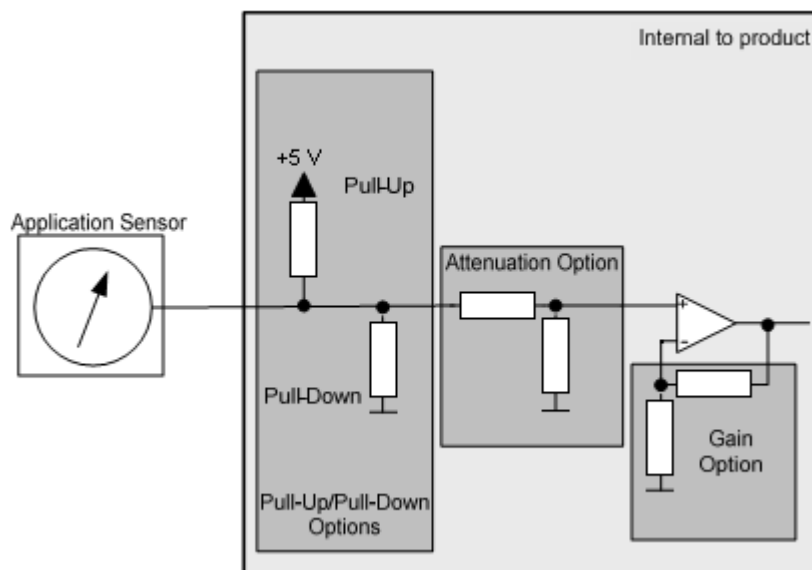

Figure 6: Analog input type 1 configuration

6.1.1.3. Analog Input Type 1 (Resistive Sensors) Software Considerations

The input can be configured using function

`set_ain_option(ANALOG1, OPTION_1, VALUE_1)`, where

- ANALOG1 is the targeted input (IN1_AIN)
- OPTION_1 is the configuration option to be changed
 - o AIN_ATTENUATION
 - o AIN_GAIN, or
 - o AIN_PULLUP_DOWN
- VALUE_1 is the desired value
 - o 0 = disabled/pull-up, or
 - o 1 = enabled/pull-down

By default all configuration options are initialized to 0 (disabled), and thus the input is used with unity gain and pull-up resistor.

For more information about software, refer to *CM0711 SDK Software Manual*, or contact your Parker Account Representative.

6.1.2. Analog Inputs Type 2 (General Purpose)

The CM0711 has four type 2 analog inputs:

- ANALOG_INPUT2 to ANALOG_INPUT5

6.1.2.1. Analog Input Type 2 (General Purpose) Capabilities

These inputs can be connected to 0 to 5V sensors. Examples include hall-effect sensors and potentiometers. The inputs are also capable of measuring 4mA to 20mA sensors or acting as digital inputs. Pull-up and pull-down resistor configuration for each input is software selectable.

The following table provides specifications for the CM0711's analog input type 2:

Table 2: Analog Input Type 2 Specifications

Item	Min	Nom	Max	Units
Input voltage range, voltage measurement	0		5.5	V
Input current range, current measurement	0		30	mA
Pull-up resistance		6950		Ω
Pull-up voltage	4.85	5.0	5.15	V
Pull-down resistance		2110		Ω
Pull-down resistance, current measurement		140		Ω
Minimum -ve going threshold	Software configurable			
Maximum +ve going threshold	Software configurable			
Cutoff frequency		51		Hz
Over-current switch-off limit, current measurement resistor		30		mA
Wetting current 24 V pulled down 12 V pulled down		11.4 5.7		mA mA
Resolution Voltage measurement Current measurement		6 0.05	10	bits mV mA
Accuracy			3	%
ADC reference voltage	3.250	3.3	3.350	V
Over-voltage tolerance	36			V
Input pin capacitance		10		nF

INFORMATION

To prevent aliasing, the sampling rate must be greater than twice the frequency of the filter or the input signal, according to the Nyquist criterion.

6.1.2.2. Analog Input Type 2 (General Purpose) Configuration

Software selectable pull-up and pull-down resistor configuration:

- 6950 Ω pull-up to 5 V
- 2110 Ω pull-down to ground
- 140 Ω pull-down to ground for current measurements.

**WARNING**

If more than one of the inputs with pull-up to 5 V configuration have simultaneous over-voltage fault, the pull-up voltage may rise higher than 5 V. This may result in faulty results from other inputs with pull-up to 5 V. The application software must be written to determine how the CM0711 will behave when the 5 V pull-up voltage is out of range.

Digital input configuration:

- Software configurable threshold voltages in range 0 to 5.5 V

The following diagram shows the configuration for type 2 analog inputs:

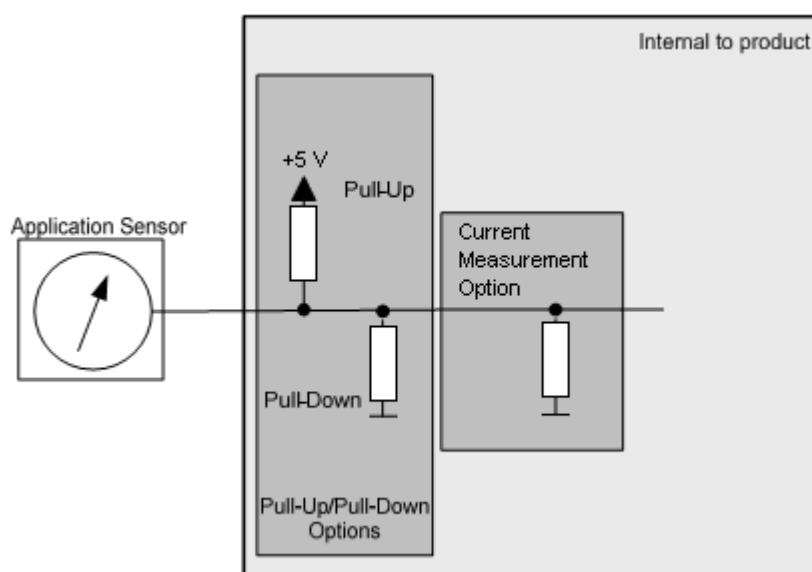

Figure 7: Analog input type 2 configuration

6.1.2.3. Analog Input Type 2 (General Purpose) Software Considerations

The input can be configured using function

`set_ain_option(ANALOG1, OPTION_1, VALUE_1)`, where

- ANALOG1 is the targeted input (IN2_AIN to IN5_AIN)
- OPTION_1 is the configuration option to be changed (AIN_PULLUP_DOWN or current mode³)
- VALUE_1 is the desired value
 - o 0 = disabled/pull-up, or
 - o 1 = enabled/pull-down

By default all configuration options are initialized to 0 (disabled), and thus the input is used in voltage measurement mode with pull-up resistor.

³ Refer to separate release schedule for software support to certain functions.

For more information about software, refer to *CM0711 SDK Software Manual*, or contact your Parker Account Representative.

6.1.3. Analog Input Installation Connections

When connecting analog inputs there are two issues you must be aware of: system noise and ground shift.

System Noise

Analog inputs are more susceptible to system noise than digital inputs. Too much system noise can create inaccurate analog input readings.

To reduce system noise

- Use the shortest possible wires when connecting sensors to analog inputs, to prevent noise pickup on the sensors.

The following shows how to connect analog inputs to reduce system noise:

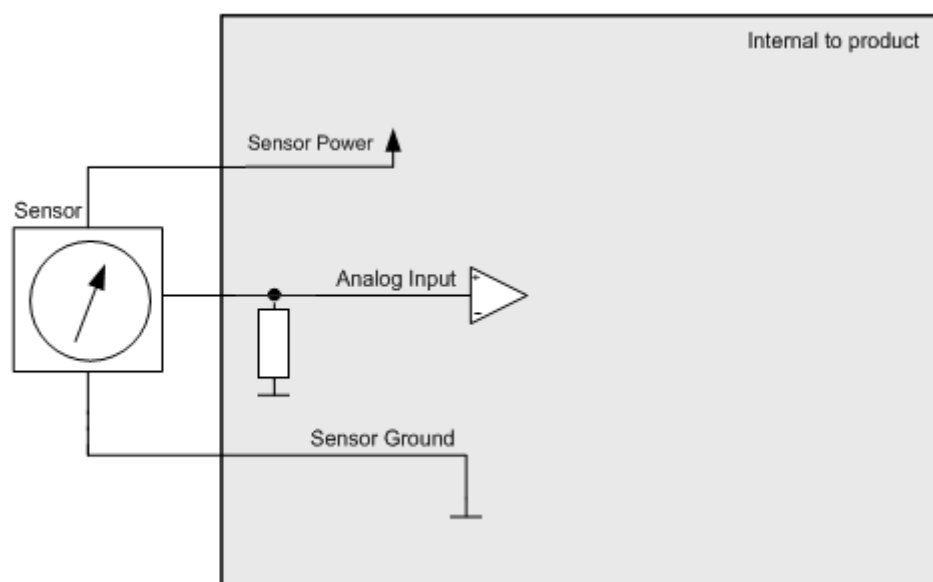

Figure 8: Analog input system noise connection

Ground Shift

The accuracy of analog inputs can be affected by ground shift. Ground shift refers to the difference between the module ground voltage and the sensor ground voltage.

To reduce ground shift for sensors that have dedicated ground wires

- Dedicate the sensor ground pin (`SENSOR_GND`) to sensors that have dedicated ground wires, and connect all sensor grounds to this ground pin.

The following shows how to address ground shift with sensors that have dedicated ground wires:

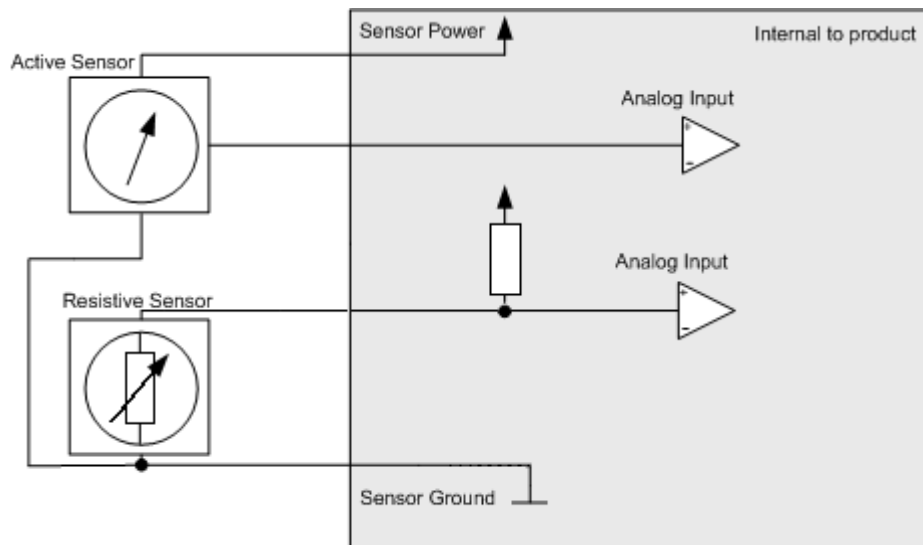

Figure 9: Typical analog input connection

6.2. Frequency Inputs

The CM0711 has two frequency inputs:

- `FREQ_INPUT1` and `FREQ_INPUT2`

6.2.1. Frequency Input Capabilities

These inputs are capable of measuring frequency, pulse counts, duty cycle and quadrature sensors.⁴ The frequency inputs are DC-coupled: the measured signals shall have a ground reference and no large DC offset. For diagnostics, the frequency inputs have analog voltage measurement. Thus the inputs can alternatively be used as analog voltage inputs, or they can also be used as digital inputs.

The following table provides specifications for the CM0711's frequency inputs:

Table 3: Frequency Input Specifications

Item	Min	Nom	Max	Units
Input voltage range	0		5	V
Pull-down resistance		7996		Ω
-ve going threshold	0.8	1.7		V
+ve going threshold		3.0	4.4	V
Frequency input cutoff frequency		37.1		kHz
Frequency range	1		15000	Hz
Frequency resolution		1		Hz

⁴ Refer to separate release schedule for software support to certain functions.

Item	Min	Nom	Max	Units
Frequency accuracy			±(1% of reading + 1 Hz)	
Analog input voltage range	0		35	V
Analog resolution		36	10	bits mV
Analog accuracy			3	%
Analog input cutoff frequency		112		Hz
ADC reference voltage	3.250	3.3	3.350	V
Over-voltage tolerance	36			V
Input pin capacitance		10		nF

6.2.2. Frequency Input Configuration

Analog input configuration

Digital input configuration

- Software configurable threshold voltages in range 0 to 35 V

6.2.3. Frequency Input Software Considerations

For more information about software, refer to *CM0711 SDK Software Manual*, or contact your Parker Account Representative.

6.2.4. Frequency Input Installation Connections

When connecting DC-coupled frequency inputs, there are two issues you must be aware of: system noise and ground shift.

System Noise

Frequency inputs are more susceptible to system noise than digital inputs.

To reduce system noise

- Connect frequency inputs to sensors that produce signals with no DC offset.
- Use the shortest possible wires when connecting frequency inputs to sensors to prevent noise pickup on the sensors.

Ground Shift

Ground shift affects the accuracy of DC-coupled frequency inputs. Ground shift refers to the difference between the module ground voltage, and the sensor ground voltage.

To reduce ground shift

- Dedicate the sensor ground pin (`SENSOR_GND`) to sensors that have dedicated ground wires, and connect all sensor grounds to this ground pin.

The following shows a typical frequency input connection:

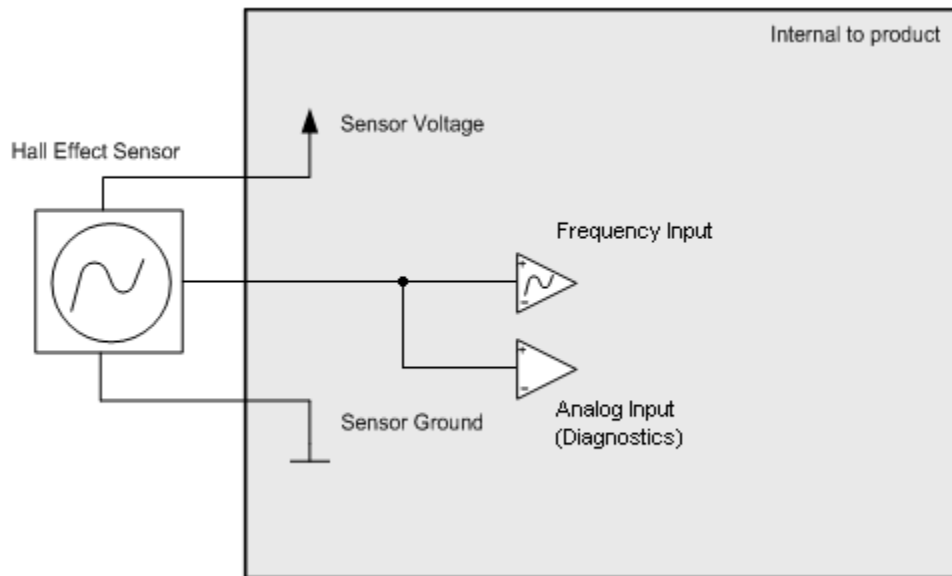

Figure 10: Frequency input installation connections

7. Outputs

The CM0711 has three types of outputs:

- High side outputs type 1 (low current)
- High side output type 2 (high current)
- Low side outputs

INFORMATION

A high side and a low side output can be coupled in the external harness to create a half-bridge.⁵ An H-bridge output can be created from 2 half-bridges, allowing 2 full H-bridge outputs to be produced (refer to section 13.6 Controlling a Linear Actuator for an example of how to use an H-bridge). For current feedback control applications, the low side outputs can be used as current return paths providing the current sensing.

7.1. High Side Outputs

The CM0711 has six type 1 high side outputs:

- HS_OUTPUT1 to HS_OUTPUT6

and one type 2 high side output:

- HS_OUTPUT7

7.1.1. High Side Output Capabilities

High side outputs are used for switching voltage to loads using either a pulse width modulated (PWM) signal, or an on/off signal. These outputs can be used to drive a variety of loads such as LEDs, relays and solenoids. Type 1 high side outputs can drive up to 2 A and Type 2 high side outputs up to 5 A. The outputs are provided with flyback (free-wheeling) diodes that provide protection when driving inductive loads. The module is able to detect open, short to ground and short to battery voltage faults on these drivers.

- When a high side output is used as an on/off signal, the output provides battery voltage when in the "on" state. The output is switched on and off as required by the application software.
- When a high side output is used as a PWM signal, a pulsed output signal is provided by the CM0711, where the percentage of time that the output is "on" vs. "off" is determined by the duty cycle of the signal, and the duty cycle is determined by the application software. The PWM frequency can be configured through the application software, and it is common for all PWM outputs.

⁵ Refer to separate release schedule for software support to certain functions.

7.1.1.1. Type 1 (Low Current)

The following table provides specifications for the CM0711's high side output type 1:

Table 4: High Side Output Type 1 Specifications

Item	Min	Nom	Max	Units
Switchable voltage range	0		36	V
Output current				
12V system	0		2.0	A
24V system				
PWM up to 200 Hz	0		2.0	A
PWM up to 350 Hz	0		1.5	A
PWM up to 500 Hz	0		1.0	A
Load resistance				
12V system	7			Ω
24V system	14			Ω
Over-voltage tolerance	36			V
PWM frequency ⁶			500	Hz
PWM resolution ⁷		0.1		%
Inductive pulse protection	Yes			
Output pin capacitance		10		nF
Output leakage – off state		1	5	μ A
Output slew rate – rising edge ⁸	0.2		1.0	V/ μ s
Output slew rate – falling edge ⁹	0.2		1.1	V/ μ s
Output enable delay ¹⁰		100	250	μ s
Output disable delay ¹¹		100	270	μ s
Feedback minimum -ve going threshold	0.8			V
Feedback maximum +ve going threshold			4.4	V
Open load detection resistance		10		k Ω

⁶ All PWM outputs operate at same frequency. Notice the frequency limitations by supply voltage and output current.

⁷ The actual value is dependent on the base frequency because the counter used for this operation has a finite number of steps.

⁸ Slew rate from driver component specification. 10 to 30% V_{OUT} , Supply=12V, $R_L = 12 \Omega$.

⁹ Slew rate from driver component specification. 70 to 40% V_{OUT} , Supply=12V, $R_L = 12 \Omega$.

¹⁰ Specifies the time in which the output achieves 90% enabled output voltage level. Control delay is ignored (only delay of the driver component is included.) Supply=12V, $R_L = 12 \Omega$.

¹¹ Specifies the time in which the output achieves 10% enabled output voltage level. Control delay is ignored (only delay of the driver component is included.) Supply=12V, $R_L = 12 \Omega$.

7.1.1.2. Type 2 (High Current)

The following table provides specifications for the CM0711's high side output type 2:

Table 5: High Side Output Type 2 Specifications

Item	Min	Nom	Max	Units
Switchable voltage range	0		36	V
Output current				
12V system	0		5.0	A
24V system				
PWM up to 100 Hz	0		5.0	A
PWM up to 200 Hz	0		4.0	A
PWM up to 350 Hz	0		3.0	A
PWM up to 500 Hz	0		2.0	A
Load resistance				
12V system	2.8			Ω
24V system	5.6			Ω
Over-voltage tolerance	36			V
PWM frequency ¹²	31		500	Hz
PWM resolution ¹³		0.1		%
Inductive pulse protection	Yes			
Output pin capacitance		10		nF
Output leakage – off state		2	10	μ A
Output slew rate – rising edge ¹⁴	0.2		1.0	V/ μ s
Output slew rate – falling edge ¹⁵	0.2		1.1	V/ μ s
Output enable delay ¹⁶		100	250	μ s
Output disable delay ¹⁷		100	270	μ s
Feedback minimum -ve going threshold	0.8			V
Feedback maximum +ve going threshold			4.4	V
Open load detection resistance		10		k Ω

¹² All PWM outputs operate at same frequency. Notice the frequency limitations by supply voltage and output current.

¹³ The actual value is dependent on the base frequency because the counter used for this operation has a finite number of steps.

¹⁴ Slew rate from driver component specification. 10 to 30% V_{OUT} , Supply=12V, $R_L = 12 \Omega$.

¹⁵ Slew rate from driver component specification. 70 to 40% V_{OUT} , Supply=12V, $R_L = 12 \Omega$.

¹⁶ Specifies the time in which the output achieves 90% enabled output voltage level. Control delay is ignored (only delay of the driver component is included.) Supply=12V, $R_L = 12 \Omega$.

¹⁷ Specifies the time in which the output achieves 10% enabled output voltage level. Control delay is ignored (only delay of the driver component is included.) Supply=12V, $R_L = 12 \Omega$.

7.1.2. High Side Output Configuration

Software controlled pull-ups

- For continuous fault detection, the CM0711 can be configured to continuously inject low-level current into the load.
- For strobed fault detection, the application software in the CM0711 will determine when to inject low-level current into the load. Strobed fault detection is useful when the load that needs to be monitored cannot be permanently connected to a 10 kΩ pull-up, and is typically used with LEDs.

Digital input configuration

- Software selectable 10 kΩ pull-up (for all high side outputs simultaneously).

The following diagrams show the configuration options for high side outputs:

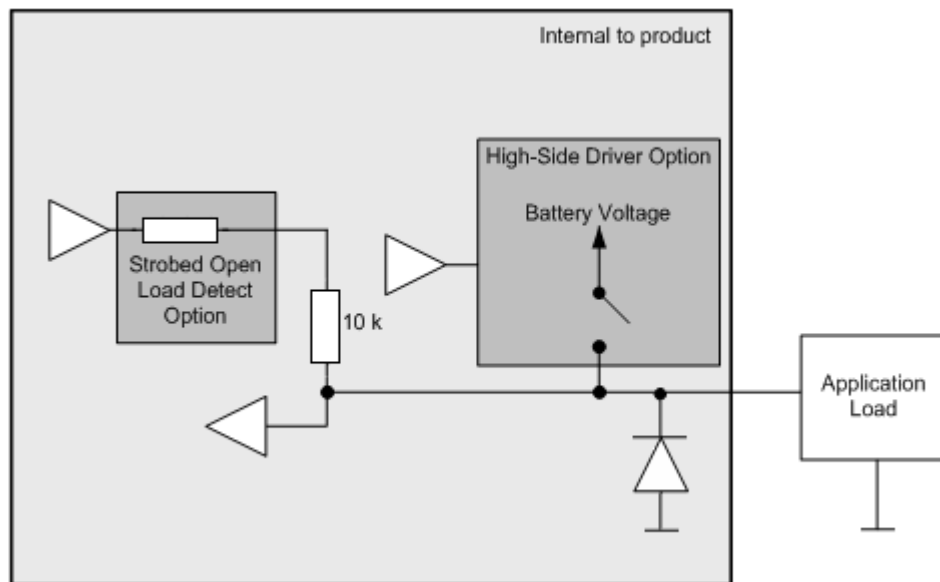

Figure 11: High side output configuration

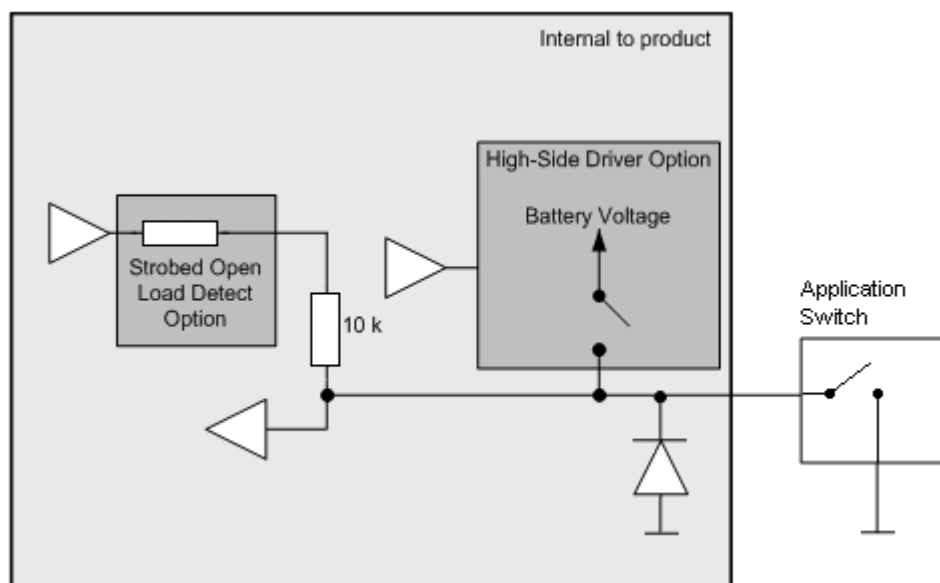

Figure 12: High-side output configured as a digital input

7.1.3. High Side Output Software Considerations

PWM frequency and duty cycle can be set using functions `set_output_pwm_frequency` and `set_output_pwm_duty`. By default the PWM frequency is initialized to 100 Hz and duty cycle to 0. The PWM frequency is common for all PWM outputs of the CM0711.

The outputs can be set on and off using functions `turn_output_on` and `turn_output_off`. By default the outputs are initialized to be off.

The output feedback state can be queried using function `get_output_state`. By default initialization the open load strobe is enabled.

For more information about software, refer to *CM0711 SDK Software Manual*, or contact your Parker Account Representative.

7.1.4. High Side Output Installation Connections

You must be aware of the following when connecting high side outputs:

- High side outputs are connected to an internal bus bar, which can be connected to a +12 V or +24 V battery. The bus bar is connected to logic power (+VBATT), and both share the same connector pins. Refer to section 8.1 *Module Power* for more details.
- High side outputs can provide switched battery power to any load type in a vehicle.
- High side outputs type 1 can source up to 2 A and high side output type 2 up to 5 A, but the maximum current is de-rated when driving loads in 24 V system with PWM frequency higher than 100 Hz as specified in 7.1.1 *High Side Output Capabilities*.
- High side outputs have internal flyback diodes, which are needed when driving inductive loads (the flyback diodes absorb electrical energy when the load is turned off).

INFORMATION

Inductive loads will create an average current flow that moves out of the high side output. When the output is on, the current flows through the output driver, and when the output is off, the current flows through the flyback diode. A duty cycle of 50% will produce the worst case average current flow through these two devices.



NOTICE

If large inductive loads are used, and the high side output is providing a continuous PWM signal, then the PWM peak current must not be greater than the specified current for the output (in continuous mode, the average current flow through the diode at 50% duty cycle is approximately equal to ½ the peak current).

When connecting high side outputs, ensure you follow these best practices:

- High side outputs should not be connected to loads that will draw currents greater than the maximum peak current, or maximum continuous current.

- The grounds for the loads should be connected physically close to the CM0711 power grounds.

The following shows a typical high side output connection:

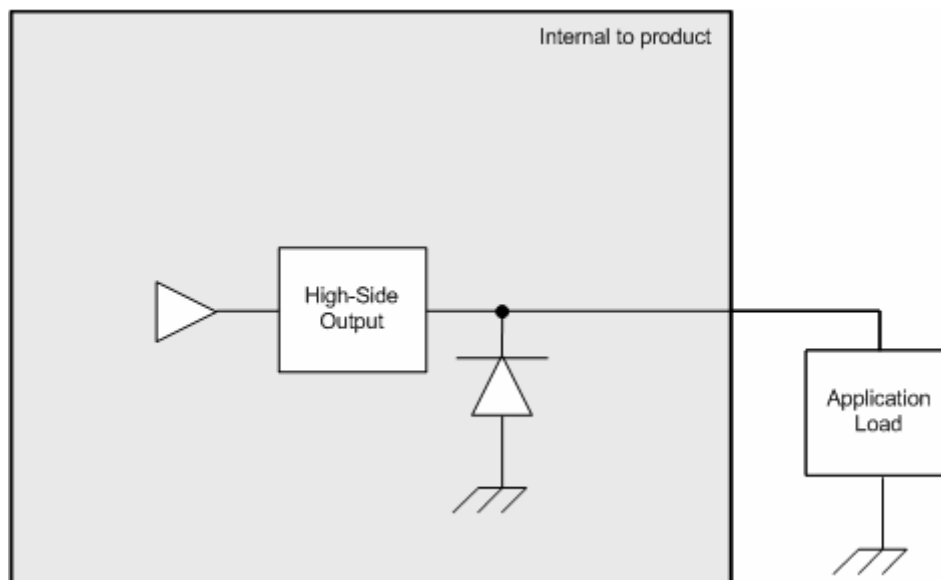

Figure 13: Typical high side output installation connections

7.1.5. High Side Output Diagnostics and Fault Protection

Each high side output has the ability to report many different fault conditions.

The types of faults that are reported are determined by the configuration of your high side outputs, and this configuration must be considered when writing the application software (refer to section 7.1.2 *High Side Output Configuration* for more details).

7.1.5.1. Short-Circuit and Over-Current

Short-circuit faults occur when a high side output pin is shorted to ground and produces an output current above the specified range, causing an over-current on the circuit.

High side outputs detect and protect against short-circuit and over-current faults, and the software automatically turns off the output when either of these faults is detected.¹⁸

The application software can be used to reset an output from an over-current or short-circuit fault, by turning the output "off" and then "on" again.¹⁹

7.1.5.2. Open Load

Open load faults occur when a high side output pin is open circuit (not connected to a load).

¹⁸ Refer to separate release schedule for software support to certain functions.

¹⁹ Refer to separate release schedule for software support to certain functions.

The high side output circuit uses voltage on the output pin to determine if an open load condition exists.

High side outputs must be “off” to detect an open-load fault.

High side outputs must be configured correctly to detect open loads (refer to section 7.1.2 *High Side Output Configuration* for more details).

7.1.5.3. Short-to-Battery

Short-to-battery faults occur when a high side output pin is connected to battery voltage.

The high side output circuit uses voltage on the output pin to determine if a short-to-battery condition exists.

High side outputs must be “off” to detect a short-to-battery fault.

The output must be configured correctly for high side outputs to be able to detect short-to-battery (refer to section 7.1.2 *High Side Output Configuration* for more details).

7.2. Low Side Outputs

The CM0711 has 4 low side outputs:

- LS_OUTPUT_1 to LS_OUTPUT_4

7.2.1. Low Side Output Capabilities

Low side outputs with current sense are used for switching grounds to loads using either a pulse width modulated (PWM) signal, or an on/off signal. These outputs can be used to drive a variety of loads such as LEDs, relays and solenoids, up to 2 A. They also have the ability to sense current that is provided to loads, through an amplifier circuit. The outputs are provided with flyback (free-wheeling) diodes that provide protection when driving inductive loads.

- When low side outputs are used as an on/off signal, the output provides ground when in the “on” state. The output is switched on and off as required by the application software.
- When a low side output is used as a PWM signal, a pulsed output signal is provided by the CM0711, where the percentage of time that the output is “on” vs. “off” is determined by the duty cycle of the signal, and the duty cycle is determined by the application software. The PWM frequency can be configured through the application software, and it is common for all PWM outputs.
- When low side outputs are used to sense current, the application software will monitor the current flowing into the low side output, and based on the amount of current, will turn the output either “on” or “off”.
 - Current flow to sense circuit gets interrupted when using low side outputs as a PWM signal, because the outputs are not “on” continuously. Therefore, current feedback control systems should use a high side output for PWM signals, and a low side output (turned on at 100%) for sensing current.

- o The application software will protect the current sense circuit from an over-current or short-circuit event when the current exceeds an allowable current range specified in the table below.

The following table provides specifications for the CM0711's low side outputs:

Table 6: Low Side Output Specifications

Item	Min	Nom	Max	Units
Switchable voltage range	0		36	V
Output current				
12V system	0		2.0	A
24V system				
PWM up to 200 Hz	0		2.0	A
PWM up to 350 Hz	0		1.5	A
PWM up to 500 Hz	0		1.0	A
Load resistance				
12V system	7			Ω
24V system	14			Ω
Over-voltage tolerance	36			V
Over-current switch-off limit		2.5		A
Current sense Amp range	0		2.5	A
Current sense resolution		3.2		mA
Current sense accuracy			5	%
Current sense repeatability on 0.2 – 2.5 A range			1	%
PWM frequency ²⁰	31		500	Hz
PWM resolution ²¹		0.1		%
Inductive pulse protection	Yes			
Output pin capacitance		10		nF
Output leakage – off state		1.5	15	μ A
Output slew rate – rising edge ²²		0.3	1.5	V/ μ s
Output slew rate – falling edge ²³		0.7	1.5	V/ μ s
Output enable delay ²⁴		60	100	μ s
Output disable delay ²⁵		60	100	μ s

²⁰ All PWM outputs operate at same frequency. Notice the frequency limitations by supply voltage and output current.

²¹ The actual value is dependent on the base frequency because the counter used for this operation has a finite number of steps.

²² Slew rate from driver component specification. 70 to 50% V_{OUT} , Supply=12V, R_L =4.7 Ω , T_j = 25°C.

²³ Slew rate from driver component specification. 50 to 70% V_{OUT} , Supply=12V, R_L =4.7 Ω , T_j = 25°C.

²⁴ Specifies the time in which the output achieves 90% enabled output current level. Control delay is ignored (only delay of the driver component is included.) Supply=12V, R_L =4.7 Ω , T_j = 25°C.

²⁵ Specifies the time in which the output achieves 90% enabled output current level. Supply=12V, R_L =4.7 Ω , T_j = 25°C.

7.2.2. Low Side Outputs Configuration

The low side outputs are not configurable.

7.2.3. Low Side Output Software Considerations

PWM frequency and duty cycle can be set using functions `set_output_pwm_frequency` and `set_output_pwm_duty`. By default the PWM frequency is initialized to 100 Hz and duty cycle to 0. The PWM frequency is common for all PWM outputs of the CM0711.

The outputs can be set on and off using functions `turn_output_on` and `turn_output_off`. By default the outputs are initialized to be off.

The output feedback state can be queried using function `get_output_state`.

For more information about software, refer to *CM0711 SDK Software Manual*, or contact your Parker Account Representative.

7.2.4. Low Side Outputs Installation Connections

You must be aware of the following when connecting low side outputs:

- Low side outputs are connected to a common internal ground point that is connected to the battery ground ($-VBATT$). Refer to section 8.1 *Module Power* for more details about the battery ground.
- Low side outputs provide switched ground to any load type in a vehicle.
- Low side outputs can sink up to **2 A**, but the maximum current is de-rated when driving loads in 24 V system with PWM frequency higher than 200 Hz as specified in 7.2.1 *Low Side Output Capabilities*.
- Low side outputs have internal flyback diodes, which are needed when driving inductive loads (the flyback diodes absorb electrical energy when the load is turned off).



WARNING

The flyback diodes feed the power from the CM0711's low side outputs to vehicle's battery system through the module power connection.

Even the CM0711's module power is not connected; power fed through low side outputs can start up the CM0711, if `IGNITION_INPUT` is high.

The system designer must ensure this will not cause unwanted vehicle responses.

The following shows a typical low side output connection:

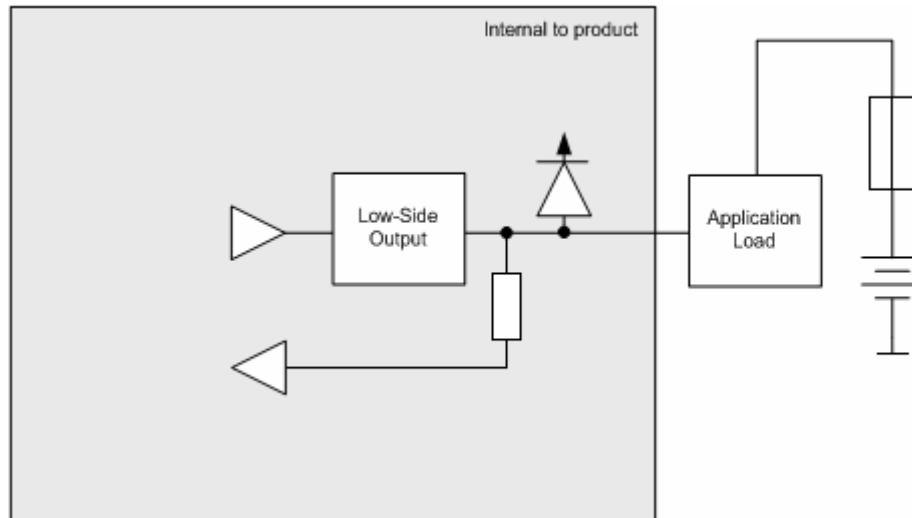

Figure 14: Low side outputs installation connections

7.2.5. Low Side Outputs Diagnostics and Fault Protection

The CM0711's low side outputs have the ability to report many different fault conditions, and are protected against short-circuit and over-current, open load, and short-to-ground faults.

7.2.5.1. Short-Circuit and Over-Current

Short-circuit faults occur when a low side output pin is shorted to battery and produces an output current above the specified range, causing an over-current on the circuit.

When a short-circuit or over-current fault is detected, the software automatically turns off the output.

The application software can be used to reset an output from an over-current or short-circuit fault, by turning the output "off" and then "on" again.²⁶

7.2.5.2. Open Load and Short-to-Ground

Open load faults occur when a low side output pin is open circuit (not connected to a load). Short-to-ground faults occur when a low side output pin is connected to ground.

The low side output circuit uses current on the output pin to determine if an open load or short-to-ground condition exists.

Low side outputs must be "on" to detect these faults.

The CM0711 does not differentiate between open-load and short-to-ground faults as they seem similar for the CM0711 (no current flow).

²⁶ Refer to separate release schedule for software support to certain functions.

8. Power

The CM0711 is powered by the vehicle battery. The CM0711 operates in a 12 V or 24 V system, and can operate down to 5.5 V and up to 36 V.

This section addresses two different types of power:

- Module power which is used for powering internal components of the CM0711, such as the microprocessor on the CM0711
- Sensor power which is used for powering external components outside of the CM0711, such as analog sensors on the vehicle

8.1. Module Power

The CM0711 has **3 pins** dedicated to providing module power for logic and outputs, called `+VBATT`, and **2 pins** dedicated to grounding the CM0711, called `-VBATT`. The ignition input pin is called `IGNITION_INPUT`.

The power and ground connections are paralleled over several pins to minimize voltage drops on higher current applications.

8.1.1. Module Power Capabilities

Module power fed to the CM0711 is distributed to two different types of components internal to the CM0711: logical and non-logical.

- Logical components, such as the microprocessor, logic peripherals, etc., are powered by logic power.
- Non-logical components, such as high-side outputs, low-side outputs, etc., are powered by either a battery bus bar or ground bus bar.

For diagnostics, the module power has an analog voltage measurement.

The following table provides specifications for the CM0711's module power:

Table 7: Module Power Specifications

Item	Min	Nom	Max	Units
Input voltage range	5.5		36	V
Over-voltage tolerance	36			V
Current draw in off state ²⁷			1	mA
Current draw in on state (excluding outputs)		50		mA
Voltage measurement range	0		35	V
Voltage measurement resolution		36	10	bits mV
Voltage measurement accuracy			3	%

²⁷ Current draw in off state assumes no external sources of leakage.

Item	Min	Nom	Max	Units
Inline fuse required on power pins			25	A

8.1.2. Ignition Input and Power Input Switch

Ignition input is connected to the power input switch and the microcontroller. It is used for waking-up the controller by pulling the input up. As ignition input is high, power input switch is closed, and sensor power supplies and logical components are powered. In addition, the power input switch can be held closed by the microcontroller when ignition is switched off (keep-alive function).

By detecting the state of ignition input, the application software can start its shutdown routines when the ignition is switched off. After the routines a controlled shutdown can be performed by disabling the hold-power output.

The following table provides specifications for the CM0711's ignition input:

Table 8: Ignition Input Specifications

Item	Min	Nom	Max	Units
Input voltage range	0		36	V
Pull-down resistance		9460		Ω
Minimum -ve going threshold	0.8			V
Maximum +ve going threshold			4.4	V
Maximum start-up threshold			5.6	V
Cutoff frequency		37.1		kHz
Over-voltage tolerance	36			V
Input pin capacitance		5		nF

8.1.3. Module Power Installation Connections

When connecting the CM0711 module power, you should be aware of the following:

- Module power connections are made using the +VBATT and -VBATT pins.
- Logic power and bus bar power share the same connector pins.
- The number of wires needed to connect the CM0711 power depends on the amount of current required by the application. It is recommended to use one 16 AWG wire for every 8 A of expected output current; however, this is not always true and ultimately depends on your application.
- The CM0711 is protected against reverse battery connections by an internal high-current conduction path that goes from ground to power. To protect the CM0711 from damage in a reverse battery condition, place a fast blow fuse of 25 A or less in series with the power wires in the application harness.
- All power connections to the CM0711 should be fused to protect the vehicle harness.



NOTICE

The system designer is responsible for selecting the appropriate fuses. Select fuse sizes by multiplying the maximum continuous current during normal operation by 1.333 (75% de-rating factor). Do not use slow blow fuses for this application. The fuse for module power cannot exceed 25 A

The following shows a typical logic and output power connection:

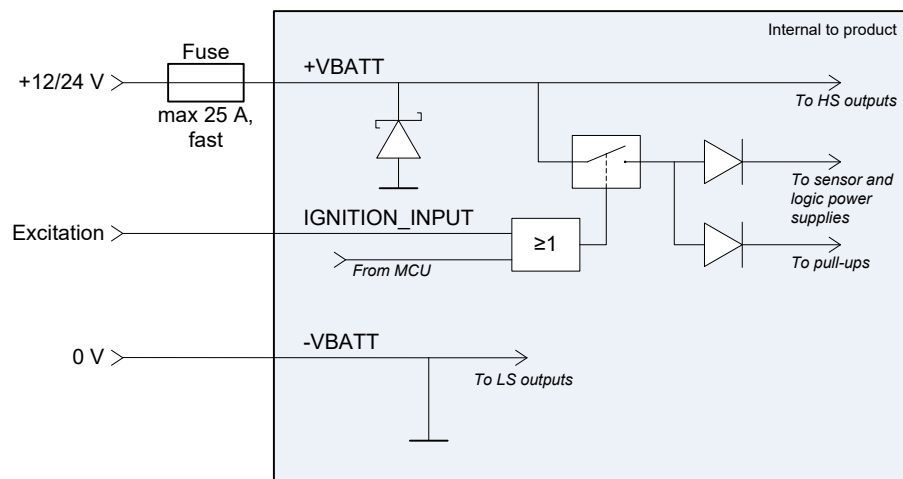

Figure 15: Logic and output power installation connections

8.2. Sensor Power

The CM0711 has one pin dedicated to providing power to external sensors called `SENSOR_SUPPLY`.



WARNING

Do not drive more than 50 mA of current through the `SENSOR_SUPPLY` pin. If you do, the pin will protect itself by dropping the voltage, which will result in a lack of power to your sensors, potentially causing unknown vehicle responses. The application software must be written to determine how the CM0711 will behave when the voltage of `SENSOR_SUPPLY` is out of range.



WARNING

If the module power voltage (battery voltage) is below 7 volts, the voltage provided by the `SENSOR_SUPPLY` pin may be lower than specified. This may result in a lack of power to your sensors, potentially causing unknown vehicle responses. The application software must be written to determine how the CM0711 will behave when the voltage of `SENSOR_SUPPLY` is out of range.

8.2.1. Sensor Power Capabilities

SENSOR_SUPPLY is a 5 V linear power supply that is capable of continuously providing up to 50 mA to external sensors. The supply voltage is proportional to +3.3V reference voltage which is also used by the A/D converter. Thus the error in reference voltage will be cancelled when the sensor power is supplying an external sensor connected to one of the module's analog inputs. For diagnostics, the sensor power has an analog voltage measurement.

The following table provides specifications for the CM0711's sensor power output:

Table 9: Sensor Power Specifications

Item	Min	Nom	Max	Units
Output voltage	4.85	5.0	5.15	V
Output current	0		50	mA
Load resistance	100			Ω
Over-voltage tolerance	40			V
Over-current limitation	51	85	120	mA
Voltage measurement range	0		6	V
Voltage measurement resolution		6.5	10	bits mV
Voltage measurement accuracy			3	%
Output pin capacitance		2.2		μ F

8.2.2. Sensor Power Installation Connections

For information on how to connect sensors, refer to section *13.7 Connecting Common Sensors*.

8.2.3. Sensor Power Diagnostics and Fault Protection

The CM0711 can measure the sensor power voltage. The application software must be written to determine how the CM0711 will behave when the voltage is out of range.

The sensor power is designed to survive short-to-battery, short-to-ground, and over-current events. If these events occur, the circuit will recover as described in the following table:

Table 10: Sensor Power Fault Recovery

Event	Recovery
Short-to-battery (sensor voltage = battery voltage)	Sensor voltage recovers when the short is removed.
Short-to-ground (sensor voltage = ground)	Sensor voltage recovers when the short is removed.
Over-current (sensor voltage = ground)	Sensor voltage recovers when the over-current condition is removed.

9. Microcontroller, Memory and Internal Diagnostics

The microcontroller used in the CM0711 is MPC5604P which is a member of Freescale’s 32-bit Qorivva/5xxx Power Architecture automotive microcontroller family with e200z0 core. The microcontroller has 40 KB RAM and 512 + 64 KB flash memory, and it runs at 64 MHz operation frequency.

9.1. Analog to Digital (A/D) Converter

The microcontroller has two internal 10-bit A/D converters.

A/D converters are used to convert voltages from analog inputs and module ID input, diagnostic feedback signals from frequency inputs and currents from low side outputs. They also convert internal diagnostic signals measuring module temperature, module power, sensor power and 5V voltage for input pull-ups.

The following table provides the specifications for the A/D converter:

Table 11: A/D Converter Specifications

Item	Min	Nom	Max	Units
A/D conversion time for signals connected directly to the micro	0.650	4.75		µs
AD Converter sampling rate		2		ms
Range of digital values	0		1023	
A/D reference accuracy			1.5	%

The sampling rate is defined in Platform framework software level.

9.2. SRAM

The microcontroller provides 40 KB of on-chip volatile static random access memory (SRAM) with error-correcting code. SRAM can hold instructions and data.

The following table provides specifications for SRAM:

Table 12: SRAM Specifications

Item	Min	Nom	Max	Units
Memory size		40		KB
Wait states required				
Read		0	1	
Write		0	2	

9.3. Flash Memory

The CM0711 microcontroller has 512 + 64 KB on-chip flash memory and 64 Mbit external serial flash memory²⁸.

The microcontroller provides 576 KB of programmable, non-volatile flash memory with error-correcting code. The non-volatile memory can be used for instruction and/or data storage. The flash memory comprises a platform flash controller interface and two flash memory arrays: one array of 512 KB for code (code flash) and one array of 64 KB for EEPROM emulation (data flash).

The following table provides specifications for the microcontroller's internal flash memory:

Table 13: Microcontroller's Internal Flash Memory Specifications

Item	Min	Nom	Max	Units
Memory size (code flash memory)		512		KB
Memory size (data flash / EE)		64		KB
Double word (64 bits) program time		22	500	µs
16 KB block pre-program and erase time		300	5000	ms
32 KB block pre-program and erase time		400	5000	ms
128 KB block pre-program and erase time		800	7500	ms
Program/erase cycles per block for 16 KB blocks	100,000			cycles
Program/erase cycles per block for 32 KB blocks	10,000	100,000		cycles
Program/erase cycles per block for 128 KB blocks	1,000	100,000		cycles
Data retention (blocks with 0 – 1,000 P/E cycles)	20			years
Data retention (blocks with 100,000 P/E cycles)	5			years

External flash memory interfaces the microcontroller with SPI. The size of the external flash memory is 64 Mbits (8MB).

The following table provides specifications for the serial flash memory:

Table 14: External Flash Memory Specifications

Item	Min	Nom	Max	Units
Memory size		64		Mbits
Page (256 bytes) program time		1.5	3	ms

²⁸ Refer to separate release schedule for software support to certain functions.

Item	Min	Nom	Max	Units
Sector erase time (64 KB)		500	2000	ms
Endurance (per sector)		100,000		cycles
Data retention		20		years

9.4. Reset Sources

+3.3V low voltage reset monitors that the microcontroller is used only with its recommended operating supply voltage range. The module will boot up after the low voltage condition and reset delay time are passed.

The following table provides specifications for the +3.3V low voltage reset:

Table 15: +3.3V Low Voltage Reset Specifications

Item	Min	Nom	Max	Units
Falling level of VCC where a reset is asserted ($T_A = -40^{\circ}\text{C}$ to $+85^{\circ}\text{C}$)	3.00	3.08	3.16	V
Reset delay time (after power up)	140		460	ms

In addition to the external reset source, the microcontroller's internal reset generation module has several reset sources, including low voltage detectors, software watchdog timer, software reset etc.

9.5. Internal Diagnostics

The CM0711 can internally monitor following variables:

- Module power voltage (Battery voltage)
- Sensor power voltage (5V)
- 5 V pull-up voltage
- Module temperature
- Microcontroller temperature
- Microcontroller core supply

For more information about module and sensor power monitoring, refer to sections *8.1.1 Module Power Capabilities* and *8.2.1 Sensor Power Capabilities*.

For more information about microcontroller temperature and core supply monitoring, refer to *MPC5604P Datasheet*.

The following table provides specifications for the CM0711's 5V pull-up voltage and module temperature measurements:

Table 16: 5V Pull-Up Voltage and Module Temperature Measurements Specifications

Item	Min	Nom	Max	Units
5 V pull-up voltage measurement range	0		6	V
5 V pull-up voltage measurement resolution		6.5	10	bits mV

Item	Min	Nom	Max	Units
5 V pull-up voltage measurement accuracy			3	%
Module temperature measurement range	-40		125	°C

**NOTICE**

In high temperature environments, to protect the CM0711 from overheating, the application must switch off outputs if the internal module temperature exceeds +100 °C.

For reporting different module states to the user, the CM0711 has a LED indicator with following colours:

- Green
- Red
- Yellow (by lighting green and red at the same time)

10. Communication

The CM0711 uses the Controller Area Network (CAN) communication when communicating with other modules on the vehicle, or with a personal computer.

10.1. Controller Area Network (CAN)

The CM0711 has two CAN interfaces:

- CAN1 and CAN2

The CM0711 hardware provides CAN communication according to the SAE J1939 specification²⁹, making the CM0711 compatible with any CAN-based protocol through software.³⁰

CAN communication is used to communicate the status of multiple modules that are connected together in the same network.

10.1.1. J1939 CAN Capabilities

The following table provides specifications for the CAN:

Table 17: CAN Specifications

Item	MIN	NOM	MAX	UNIT
Baud rate limitations (hardware)	-	-	500	kbps
Baud rate limitations (framework)	-	250	-	kbps
Overvoltage tolerance	36			V
Onboard terminator option	N/A			
Wake on CAN option	N/A			

10.1.2. J1939 CAN Configuration

The CAN interfaces are not configurable.

INFORMATION

Putting CAN termination resistors in the module would violate the J1939 specification, which states that the resistor should be designed into the harness.

10.1.3. J1939 CAN Installation Connections

The CAN connection for the CM0711 should conform to the J1939 standard.

²⁹ The CAN driver in the CM0711 provides dominant bus voltage of minimum 2.45 V for CANH whereas J1939-11 specifies minimum dominant bus voltage for CANH to be 3.0 V. Differential dominant bus voltage from CM0711 CAN driver is from 1.5 to 3.0 V as specified by J1939-11.

³⁰ Refer to separate release schedule for software support to certain functions.

For a list of J1939 connection considerations, refer to the *SAE J1939 specifications* available through *the Society for Automotive Engineers*. SAE J1939-11 covers the physical aspects of the CAN bus including cable type, connector type, and cable lengths.

The following lists the elements that are required for a J1939 CAN connection:

- **CAN Cable:** A shielded twisted-pair cable should be used when connecting multiple modules to the CAN bus. The cable for the J1939 CAN bus has three wires: CAN High, CAN Low, and CAN Shield (which connect to the corresponding CAN_HI, CAN_LO, and CAN_SHLD pins on the connector). The CAN cable must have an impedance of 120 Ω .
 - The CAN cable is very susceptible to system noise; therefore, CAN Shield must be connected according to the following:
 - a. Connect CAN Shield to the point of least electrical noise on the CAN bus.
 - b. Connect CAN Shield as close to the centre of the CAN bus as possible.
 - c. Use the lowest impedance connection possible.



NOTICE

Ground loops can damage electronic modules. The CAN Shield can only be grounded to one point on the network. If grounded to multiple points, a ground loop may occur.

- **CAN Connectors:** Industry-approved CAN connectors are manufactured by ITT Cannon and Deutsch, and come in either “T” or “Y” configurations.
- **CAN Harness:** The CAN harness is the “main backbone” cable that is used to connect the CAN network. This cable cannot be longer than 40 metres, and must have a 120 Ω terminator resistor at each end. The 120 Ω terminator resistors eliminate bus reflections and ensure proper idle state voltage levels.
- **CAN Stubs:** The CAN stubs cannot be longer than 1 m, and each stub should vary in length to eliminate bus reflections and ensure proper idle state voltage levels.
- **Max Number of Modules in a System:** The CAN bus can handle a maximum of 30 modules in a system at one time.

The following shows a typical CAN connection using the SAE J1939 standard:

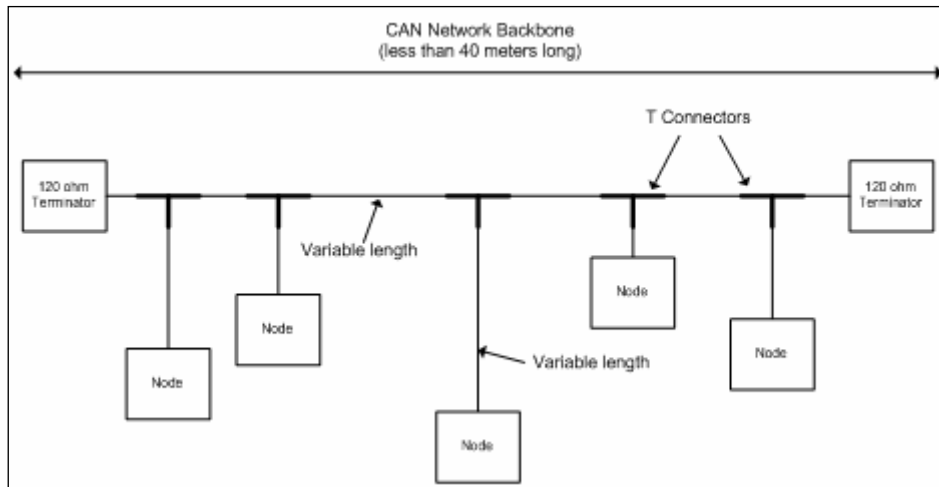

Figure 16: J1939 CAN connection

10.2. Module ID

The module can be configured by using an ID-Tag, which is connected to the connector mating the CM0711, between address high and low pins. The ID-Tag will enable a numeric input to the application which can be used to enable specific functions in the module. Each module can have a unique address. The maximum number of addresses is eight, denoted as addresses 0, 1, 2, 3, 4, 5, 6, 7 respectively. The ID-Tag can be used for CAN address selection.

For defining the module ID, the CM0711 has one module ID interface consisting of an analog module ID input:

- ADDR_L

and +3.3V reference voltage output:

- ADDR_H

10.2.1. Module ID Capabilities

An ID-Tag will be connected between ADDR-L and ADDR-H. Based on the value of this ID-Tag, the module will select its CAN address and module ID.

The ADDR-H output voltage is proportional to +3.3V reference voltage which is also used by the A/D converter.

The following table provides specifications for module ID:

Table 18: Module ID Specifications

Item	Min	Nom	Max	Units
Input voltage range	0		3.3	V
Input pull-down resistance		2000		Ω
Input resolution		3.3		mV
Input accuracy			2	%
Cut-off frequency		28		Hz

Item	Min	Nom	Max	Units
ADC reference voltage	3.250	3.3	3.350	V
Input pin over-voltage tolerance	36			V
Input pin capacitance		10		nF
Output voltage	3.20	3.3	3.40	V
Output current	0		50	mA
Output over-current limitation	51	85	120	mA
Output pin over-voltage tolerance	36			V
Output pin capacitance		2.2		μ F
Resistance	0			Ω

10.2.2. Module ID Configuration

The module ID interface is not configurable.

10.2.3. Module ID Installation Connections

The ID-Tag defining the address for the module shall be inserted to the CM0711 connector positions ADDR-H and ADDR-L.

The following shows a typical module ID connection:

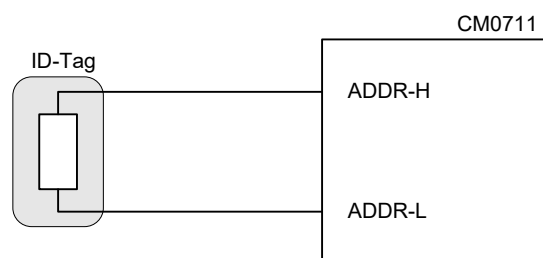

Figure 17: Module ID installation connections

10.2.4. Module ID Diagnostics and Fault Protection

Short or open circuit between ADDR-L and ADDR-H pins will generate a non-valid input voltage, as well as shorting either pin to ground or ADDR-L pin to battery voltage. However, depending on battery voltage and ID-tag value, shorting ADDR-H to battery voltage may generate an input voltage in acceptable range and thus an erratic ID value which cannot be detected.

10.2.5. ID-Tag Part Numbers

The following table provides part numbers for the ID-Tags with different addresses:

Table 19: Connector Contact Part Numbers

Address	Ordering No. (10-pack)	Resistance (Ω)
0	20085050	294
1	20085051	590
2	20085052	976
3	20085053	1.5K
4	20085054	2.23K
5	20085055	3.36K
6	20085056	5.3K
7	20085057	9.53K

INFORMATION

The ID-Tags with combined address and terminating function (0T, 1T, 2T... etc.) should not be used with the CM0711, because the CM0711 does not have onboard CAN terminator option.

INFORMATION

The ID-Tags are available from Parker. Please consult your Parker Account Representative for specific details and pricing information.

11. Connectors

There are two 18-pin Deutsch DT14-18 connectors on the CM0711, with following mating connectors:

- C1: Deutsch DT16-18SB-K004 or DT16-18SB-EK02 (black)
- C2: Deutsch DT16-18SC-K004 or DT16-18SC-EK02 (green)

The connector C2 contains all active IO-pins and the connector C1 other non-IO pins.

11.1. General

The connector pins on the CM0711 are nickel plated. Connector housings are molded in the aluminium enclosure. The mating connectors are Deutsch DT16-18 plugs. Only straight plugs are available. The connectors are keyed to prevent mismatching. The plugs are made of thermoplastic and have silicone rubber seals providing IP69K ingress protection rating. Temperature rating for the connectors is -55 °C to +125 °C.

The connectors use size 16 contacts which are rated for 13 amp continuous current. Fitting contacts are available for wire sizes 0.5 – 2.0 mm² (AWG 20 – 14) with nickel or gold plating. For environmental sealing the outer diameter of the wires should be 1.35 mm to 3.05 mm. Empty grommets in the plugs due to unused pins should be filled with sealing plugs. Contact insertion requires no tools.

It is recommended to minimize the number of engagements to avoid seal wearing. The connectors itself endure 100 cycles of engagement and disengagement without electrical or mechanical defects, but the rubber seals can wear much faster.



Figure 18: Deutsch DT16-18 plug

11.2. Mating Connector Part Numbers

Plug for connector C1 (B-coding):

- Deutsch DT16-18SB-K004, or
- Deutsch DT16-18SB-EK02 (black)

Plug for connector C2 (C-coding):

- Deutsch DT16-18SC-K004, or
- Deutsch DT16-18SC-EK02 (green)

The mating connector plugs need size 16 socket contacts. The following table provides part numbers for the contacts with different type, size and plating:

Table 20: Connector Contact Part Numbers

Part Number	Type	Wire Size (mm ²)	Plating
0462-201-16141	Solid	0.5 – 1.0	Nickel
0462-201-1631	Solid	0.5 – 1.0	Gold
0462-209-16141	Solid	1.0 – 2.0	Nickel
0462-209-1631	Solid	1.0 – 2.0	Gold
1062-16-0622	Stamped & Formed	0.5 – 1.0	Nickel
1062-16-0644	Stamped & Formed	0.5 – 1.0	Gold
1062-16-0122	Stamped & Formed	0.75 – 1.5	Nickel
1062-16-0144	Stamped & Formed	0.75 – 1.5	Gold
1062-14-0122	Stamped & Formed	1.0 – 2.0	Nickel
1062-14-0144	Stamped & Formed	1.0 – 2.0	Gold
1062-16-1222	Stamped & Formed	1.0 – 2.5	Nickel
1062-16-1244	Stamped & Formed	1.0 – 2.5	Gold
114017	Sealing plug (for empty grommet)	–	–

INFORMATION

An I/O connection kit for building harnesses for the CM0711 is available from Parker. The kit includes mating connector plugs and socket contacts for connecting one CM0711 module. The part number for the kit is 88JCM0711K2. Please consult your Parker Account Representative for specific details and pricing information.

INFORMATION

For other accessories such as assembly tools or dust caps for unmated connectors, please contact Deutsch or LADD Industries.

11.3. Connector Pin-outs

Connector pins connect to inputs, outputs, and communication channels. They provide the interface between the vehicle harness and the internal circuitry of the CM0711.

The following figures and tables show the pin-outs for each connector:

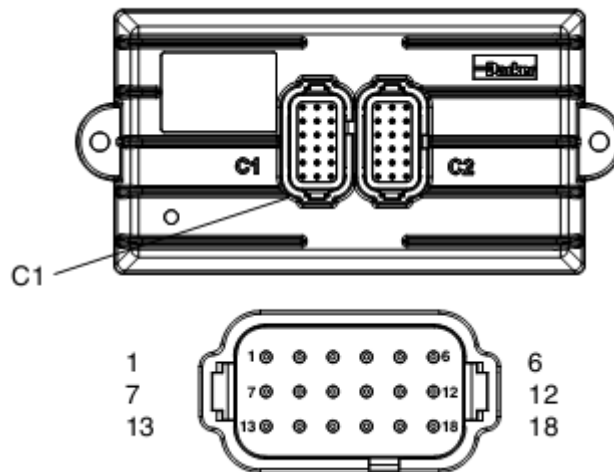

Figure 19: Connector C1

Table 21: Connector C1 (B-coding) Pin-out

Connector Pin	Name	Function
C1-01	IGNITION_INPUT	Ignition input
C1-02	CAN2_SHLD	CAN2 Shield
C1-03	CAN2_HI	CAN2 High
C1-04	CAN1_LO	CAN1 Low
C1-05	CAN1_SHLD	CAN1 Shield
C1-06	SENSOR_SUPPLY	+5V reference voltage output
C1-07	BOOTMODE	Bootmode input (for factory use only)
C1-08	NO_CONNECT	Not connected
C1-09	CAN2_LO	CAN2 Low
C1-10	CAN1_HI	CAN1 High
C1-11	SENSOR_GND	Sensor ground
C1-12	+VBATT (SUPPLY)	Module power for logic (12/24V)
C1-13	ADDR_H	Module ID reference voltage
C1-14	ADDR_L	Module ID input
C1-15	-VBATT	Module ground for logic (GND)
C1-16	-VBATT (LSO GROUND)	Module ground for outputs (GND)
C1-17	+VBATT (HSO SUPPLY)	Module power for outputs (12/24V)

Connector Pin	Name	Function
C1-18	+VBATT (HSO SUPPLY)	Module power for outputs (12/24V)

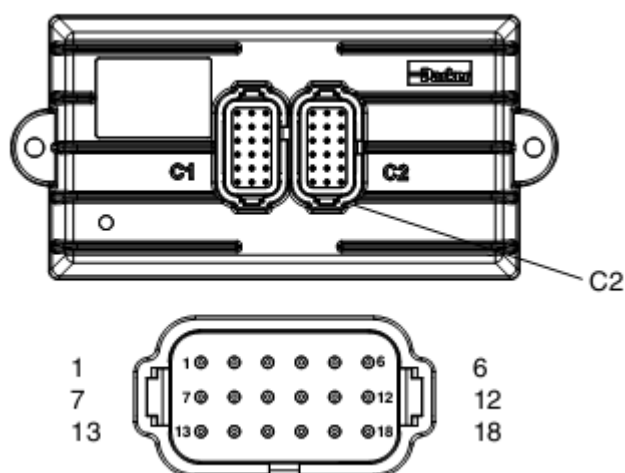

Figure 20: Connector C2

Table 22: Connector C2 (C-coding) Pin-out

Connector Pin	Name	Function
C2-01	LS_OUTPUT1	Low side output 1
C2-02	LS_OUTPUT2	Low side output 2
C2-03	ANALOG_INPUT2	Analog input 2
C2-04	ANALOG_INPUT5	Analog input 5
C2-05	HS_OUTPUT2	High side output 2 (low current)
C2-06	HS_OUTPUT1	High side output 1 (low current)
C2-07	LS_OUTPUT4	Low side output 4
C2-08	ANALOG_INPUT1	Analog input 1 (resistive sensors)
C2-09	FREQ_INPUT1	Frequency input 1
C2-10	FREQ_INPUT2	Frequency input 2
C2-11	ANALOG_INPUT3	Analog input 3 (general purpose)
C2-12	ANALOG_INPUT4	Analog input 4 (general purpose)
C2-13	LS_OUTPUT3	Low side output 3 (general purposes)
C2-14	HS_OUTPUT7	High side output 7 (high current)
C2-15	HS_OUTPUT5	High side output 5 (low current)
C2-16	HS_OUTPUT6	High side output 6 (low current)
C2-17	HS_OUTPUT3	High side output 3 (low current)
C2-18	HS_OUTPUT4	High side output 4 (low current)

12. Installing into a Vehicle

Because every system is different, it is difficult for us to provide specific instructions on how to install a CM0711 into a vehicle. Instead, we have provided mechanical, environmental, and electrical guidelines and requirements that you should be aware of before installing the product.

The vehicle manufacturer is responsible for creating procedures for mounting the CM0711 in a vehicle during production assembly.

12.1. Mechanical Guidelines

Ensure you review the following mechanical guideline sections before installing the CM0711 into a vehicle.

12.1.1. Dimensions

The outer dimensions of the CM0711 excluding plug connectors are 184.7 x 89.1 x 47.3 mm (length x width x height) and the weight is 0.6 kg.

The following diagram shows the dimensions of the CM0711:

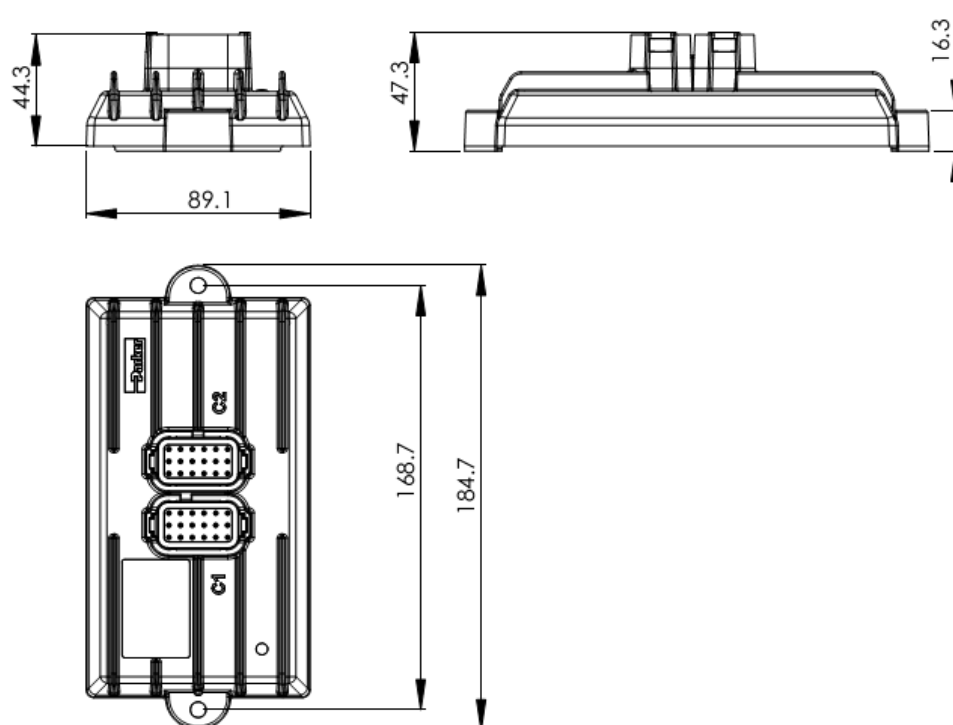

Figure 21: Dimensions

12.1.2. Selecting a Mounting Location

The CM0711 can be installed in the vehicle's cab, or on the chassis. The CM0711 is tested against salt spray, but if used for a marine application, ensure that other specific requirements for marine environment are fulfilled.

Refer to section *15 Summary of Tests* for a complete list of environmental tests the CM0711 has been tested against.

Before mounting the CM0711, ensure you review the following environmental and mechanical requirements.



NOTICE

Do not install the CM0711 close to any significant heat sources, such as a turbo, exhaust manifold, etc. Also avoid installing the CM0711 near any drive-train component, such as a transmission or engine block.

12.1.2.1. Environmental Requirements



NOTICE

The CM0711 warranty does not cover damage to the product when exposed to environmental conditions that exceed the design limitations of the product.

Review the following environmental specifications before selecting a mounting location for the CM0711:

- The CM0711 must be in an environment that is within its ambient temperature range.
 - Safe operating temperature range is **-40 °C to +85 °C**.
- The CM0711 must be in an environment that does not exceed its water or particle ingress rating.
 - The sealing standard for the CM0711 is **IP69K**.
- The CM0711 is protected from high-pressure and steam cleaning.



NOTICE

Exercise caution when pressure washing the CM0711. The severity of a pressure wash can exceed the CM0711 pressure wash specifications related to water pressure, water flow, nozzle characteristics and distance. Under certain conditions a pressure wash jet can cut wires.

12.1.2.2. Mechanical Requirements

Review the following mechanical requirements before selecting a mounting location for the CM0711:

- The CM0711 should be positioned so moisture will drain away from it.

- The harness should be shielded from harsh impact.
- The harness should connect easily to the connector and have adequate bend radius.
- The labels should be easy to read.
- The CM0711 should be easily accessible for service.

12.1.3. Mounting to a Vehicle

It is up to the original equipment manufacturer (OEM) to ensure the product is securely mounted to the vehicle.

The following guidelines are related to physically attaching the CM0711 to a vehicle:

- The CM0711 should be secured with bolts in both bolt holes using M6 hexagonal bolts and A6,4 washers. The diameter of the fixing holes is 6.4 ± 0.1 mm.
- An informational torque value for the bolts is $9\text{Nm} \pm 10\%$. Exact torque value must be found by tests and the fastener manufacturer's tightening torque specifications.
- Suggested fastening tool for bolts is 10 mm sleeve.

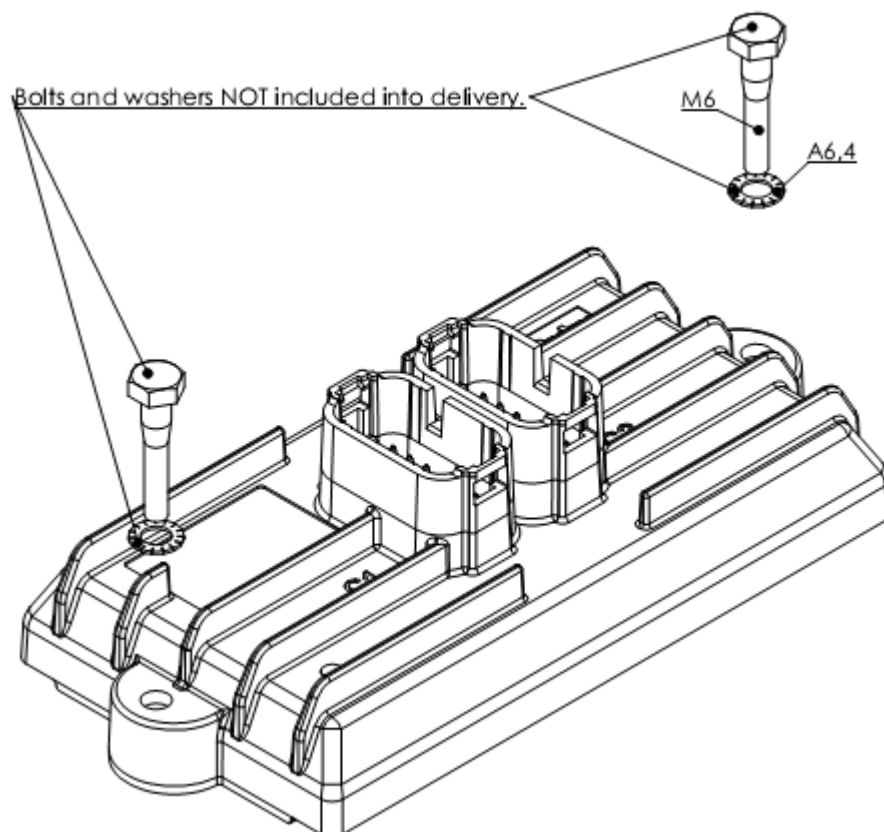

Figure 22: Mounting of the CM0711

12.2. Electrical Guidelines

The following sections provide electrical guidelines to install the CM0711 in a vehicle.

12.2.1. Designing the Vehicle Harness

The vehicle manufacturer is responsible for designing a vehicle harness that mates with the CM0711 connector(s).

The vehicle harness design depends on the following:

- How the CM0711's inputs, outputs, communication, and power pins are configured.
- Other components on the vehicle and their physical locations.
- The routing of the harness.

For guidelines and recommendations on how to connect the different elements of the CM0711, refer to the *Installation Connections* sections found within each input, output, communication, and power section in this manual.

Refer to section *11 Connectors* for details on the CM0711 connector types, pin-outs, and mating part numbers.

INFORMATION

An I/O connection kit for building harnesses for the CM0711 is available from Parker. The kit includes mating connector plugs and socket contacts for connecting one CM0711 module. The part number for the kit is 88JCM0711K2. Please consult your Parker Account Representative for specific details and pricing information.

12.2.2. Connecting the Vehicle Harness

Once the vehicle harness is designed, it can be connected to the CM0711 simply by clicking the mating connector into the connector port on the CM0711.

13. Application Examples

The purpose of this section is to provide examples of how the CM0711 can be used for different purposes.

The following examples are covered in this section:

- Implementing safety interlocks
- Controlling indicator lights
- Controlling a proportional valve
- Controlling motor speed
- Using one analog input as two digital inputs
- Controlling a linear actuator
- Connecting sensors

INFORMATION

These examples are for illustrative purposes only.

13.1. Implementing Safety Interlocks

Safety is paramount when creating controls for a vehicle.

One safety feature that can be implemented with the CM0711 is to ensure the vehicle doesn't move when it is not being used, and no one is sitting in the operator's seat.

To prevent the vehicle from moving when no one is sitting in the operator seat:

1. Place a **seat switch interlock** on the operator seat and connect the switch to a digital input.
2. Write application code for the digital input so that it shuts down critical vehicle functions when the switch is open (when no one is sitting in the seat).

INFORMATION

The example above may cause unwanted shutdowns if the operator moves around while controlling the vehicle. To prevent this, use software filtering that will prevent the vehicle from shutting down unless the switch is open for more than a defined period of time.

The following diagram shows a typical seat switch interlock connection:

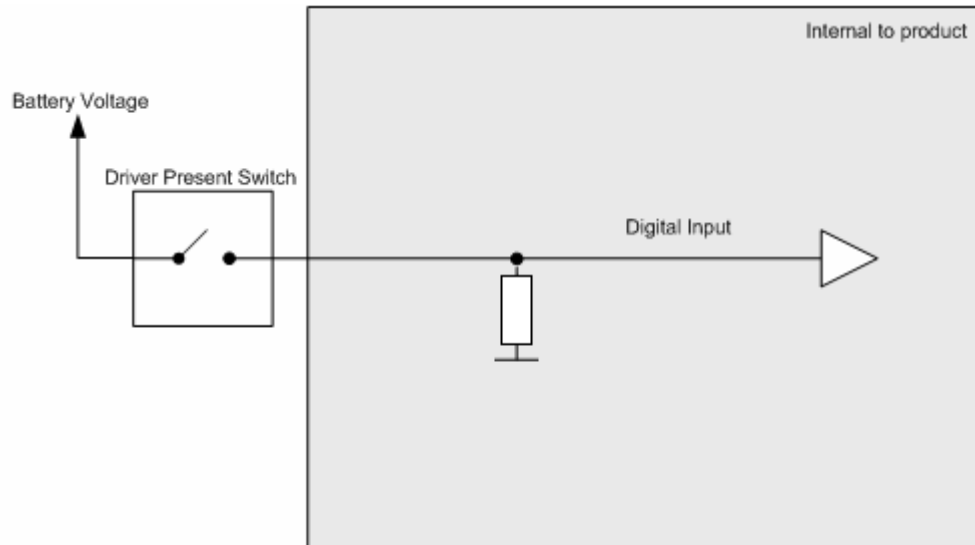

Figure 23: Seat switch interlock connection

13.2. Controlling Indicator Lights

Multiple CM0711 can be used together in a system to control a vehicle's indicator lights.

The CM0711s would communicate over CAN, and be connected according to the following:

- One CM0711 could be wired to the rear indicator lights
- One CM0711 could be wired to the front indicator lights
- One CM0711 could be wired to the turn signal and hazard switches

The following shows how to connect three CM0711s together in a system to control indicator lights:

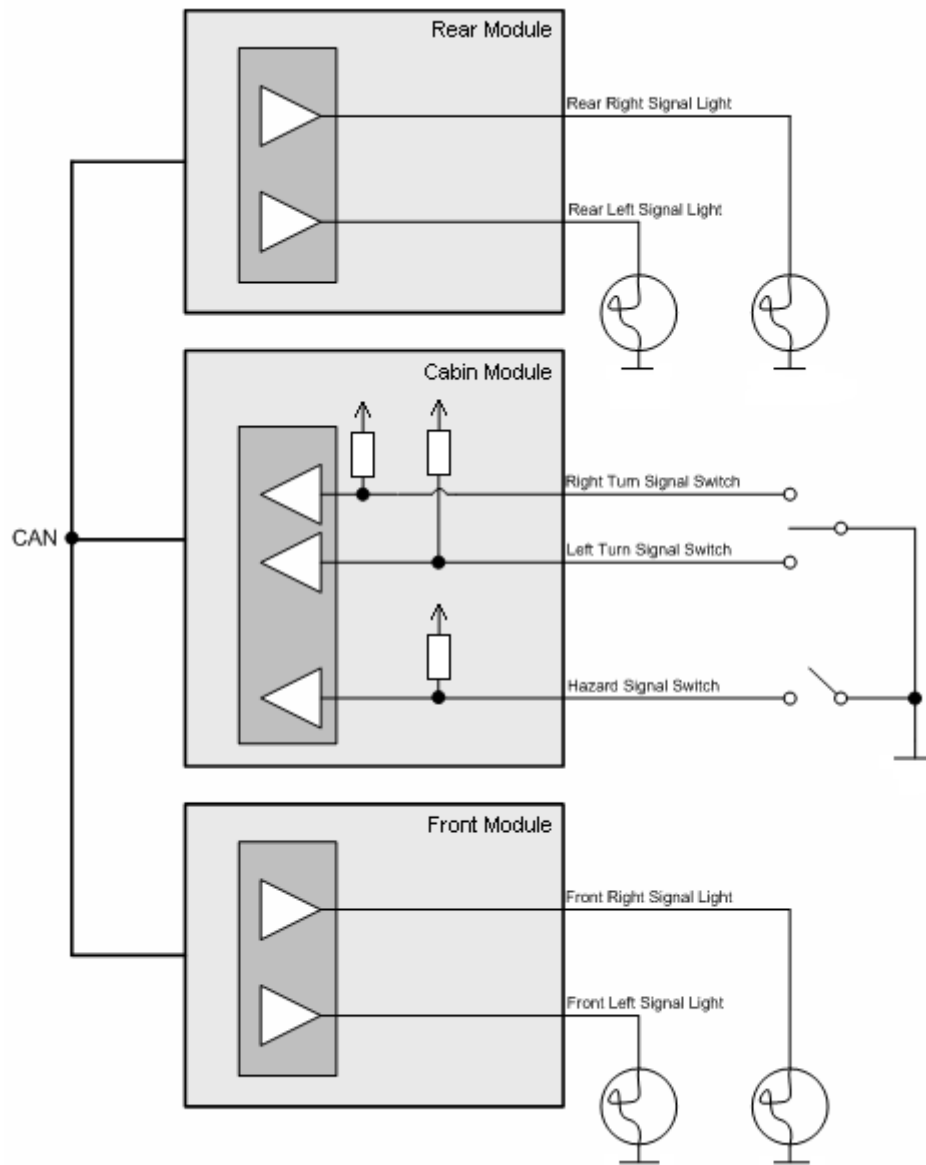

Figure 24: Indicator light connections

13.3. Controlling a Proportional Valve

INFORMATION

The CM0711 has Proportional Integral Differential (PID) capabilities that make it possible to control devices like proportional valves through software. Refer to the appropriate software manual, or contact your Parker Account Representative for more details about software. This section only provides hardware connection information.

The CM0711 can be used to control a proportional hydraulic valve through a **high side output with PWM capability**, and a **low side output with current sense**.

When making the connection, it is highly recommended to use the high side and low side outputs in pairs to avoid potential problems (use low side output 1 with high side output 1, low side output 2 with high side output 2, etc.).

- The high side output would drive power to the valve coil and adjust the duty cycle of a PWM signal.
- The low side output would be used as a return path to ground for the valve coil, and provides feedback on the amount of current flowing through the valve coil.

The application code should be written so that the PWM duty cycle for the output is adjusted to achieve a target current through the valve coil.

- If current feedback is lower than target, the PWM duty cycle should increase to boost average current through the valve coil.
- If the current feedback is higher than target, the PWM duty cycle should decrease to reduce average current through the valve coil.

The following shows how to connect a high side and low side output to control a proportional hydraulic valve:

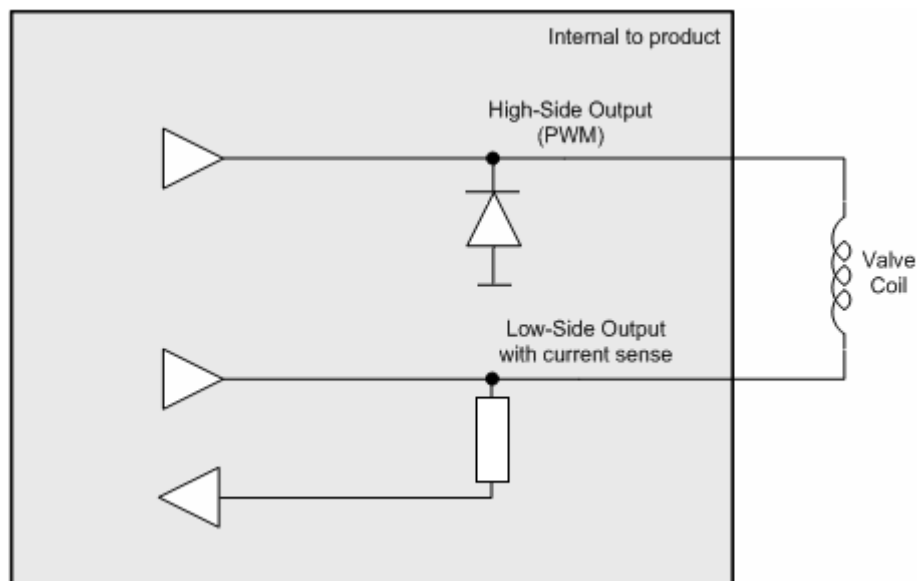

Figure 25: Connection for controlling a proportional valve

13.4. Controlling Motor Speed

INFORMATION

The CM0711 has Proportional Integral Differential (PID) capabilities that make it possible to control devices like DC motor through software. Refer to the appropriate software manual, or contact your Parker Account Representative for more details about software. This section only provides hardware connection information.

The CM0711 can be used to control the DC motor speed of motors that provide a tachometer output.

To do this, you would use a **high side output with PWM capabilities** to control the speed of the motor, and a **DC-coupled frequency input** to monitor the output from the motor.

The application code should be written so that the PWM duty cycle for the high side output is adjusted to achieve a target speed (frequency) for the motor.

- If the frequency feedback is lower than target, the PWM duty cycle should increase to boost the average current through the motor to speed it up.
- If the frequency feedback is higher than target, the PWM duty cycle should decrease to reduce average current through the motor to slow it down.

The following shows how to connect the CM0711 to control the speed of a motor:

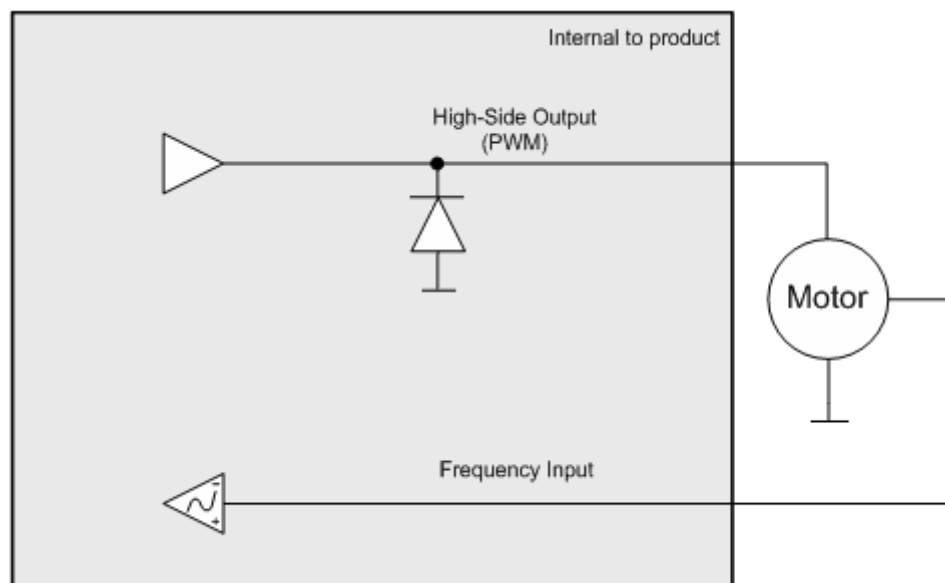

Figure 26: Connection for controlling motor speed

13.5. Using one Analog Input as Two Digital Inputs

The CM0711 allows you to use one analog input as two digital inputs, which is useful if you are running out of digital inputs in your system.

To do this, you would connect the analog input to a single pole, double throw (SPDT) switch.

INFORMATION

You will need to write software that controls the switch according to the voltage value readings provided by the analog input. Refer to the appropriate software manual, or contact your Parker Account Representative for more information on writing software.

When making the connection, ensure there is a voltage difference between the two pins on the SPDT switch. This can be done by

- enabling the internal pull-up resistor on the analog input (done through software);
- adding a resistor to one of the pins on the SPDT switch.

The following shows how to connect an analog input to a SPDT switch:

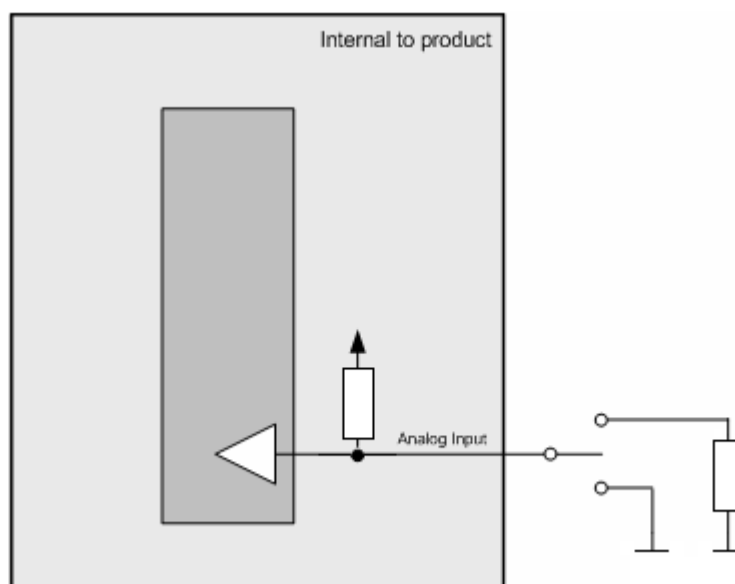

Figure 27: Connecting an analog input to an SPDT switch

13.6. Controlling a Linear Actuator

INFORMATION

The CM0711 has Proportional Integral Differential (PID) capabilities that make it possible to control devices like an electric or hydraulic linear actuator through software. Refer to the appropriate software manual, or contact your Parker Account Representative for more details about the software. This section only provides hardware connection information.

The CM0711 can control the position of a linear actuator by using **two h-bridges of high side and low side outputs**, and monitor the position of the actuator using an **analog input**. When making the connections, it is highly recommended to use the high side and low side outputs in pairs to avoid potential problems (use high side output 1 with low side output 1, etc.).

The application code should be written to adjust the PWM duty cycle and direction of the current to achieve a target position for the linear actuator.

The following shows how to connect high side and low side outputs for controlling a linear actuator:

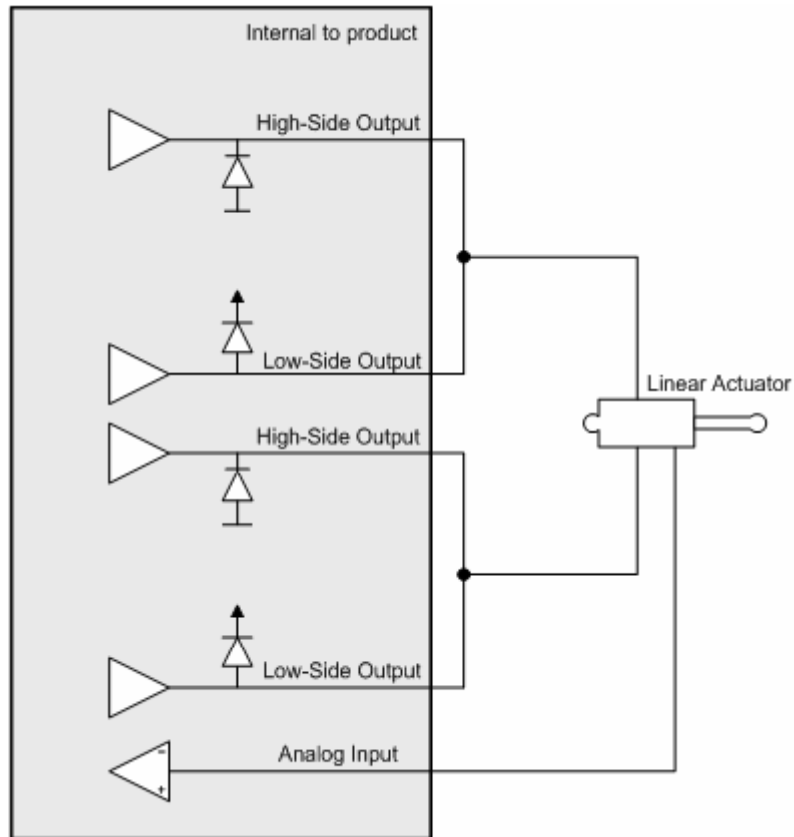

Figure 28: Connection for controlling a linear actuator

13.7. Connecting Common Sensors

There are many types of sensors that can be connected to the CM0711, the most common are as follows:

- Open collector sensors
- Switch sensors
- Voltage sensors
- Potentiometer (ratiometric) sensors

INFORMATION

To optimize the reading accuracy for sensors, dedicate sensor ground pin (called `SENSOR_GND`) as a low-current ground return for all sensors on the vehicle.

INFORMATION

When connecting sensors to the CM0711, refer to the sensor manufacturer's specifications to ensure the CM0711 is configured correctly for the sensor.

13.7.1. Open Collector Sensors

Open collector sensors are compatible with each type of input on the CM0711.

Open collector sensors are typically used in applications that require digital or frequency measurements. They work by pulling voltage down to ground or up to power when activated, and are basically a switch that turns "on" and "off".

Open collector sensors need a pull-up or pull-down resistor to bias the state of the sensor when the sensor is not activated. Pull-up and pull-down resistors are internal to the CM0711.

The following shows a typical open collector sensor connection:

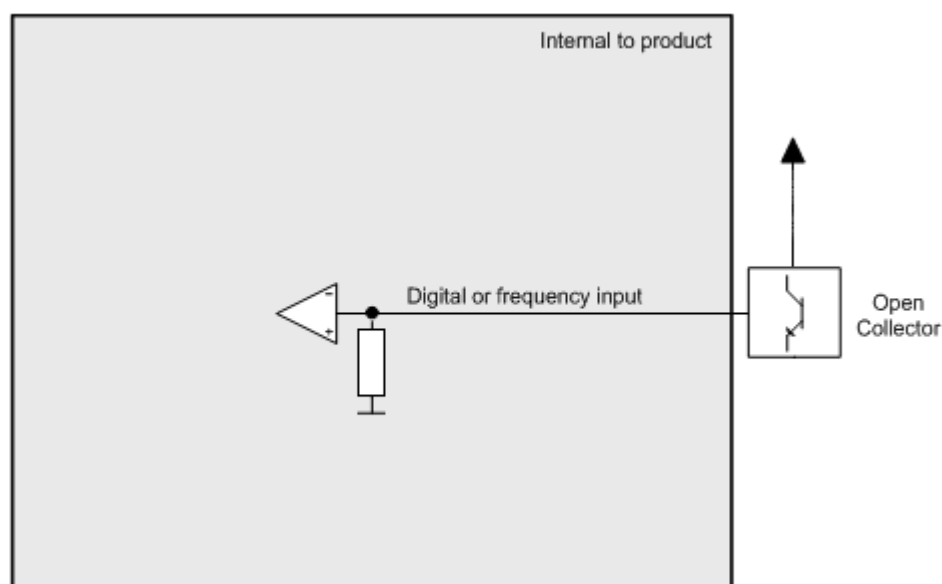

Figure 29: Open collector active high connection

13.7.2. Switch Sensors

A switch is a type of sensor that uses mechanical contacts in one of two states: open or closed. Sensor switches are used to turn sensors on and off, and can be wired directly to digital inputs.

Active-high sensor switches may be used by the CM0711. For active-high switches use an input with internal pull-down resistor.

The following shows a typical sensor switch connection:

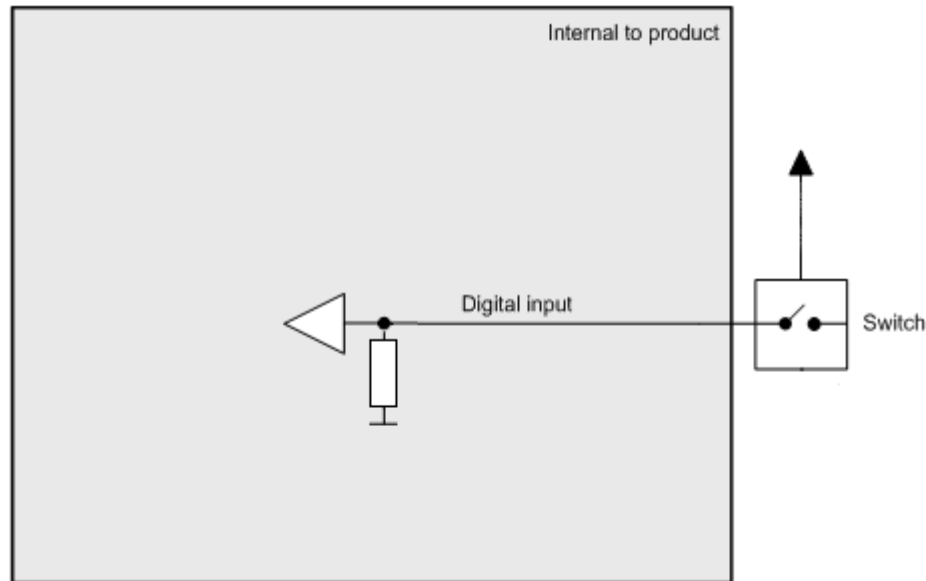

Figure 30: Switch sensor active high connection

13.7.3. Voltage Sensors

Voltage type sensors work by driving an analog voltage signal to report the sensor's measured value.

Voltage sensors are compatible with analog inputs, and are typically used in applications that require variable voltage measurements.

Ensure you configure the analog input voltage (gain and attenuation factors) so the input's voltage is close to the maximum output voltage of the sensor.

The following shows a typical voltage sensor connection:

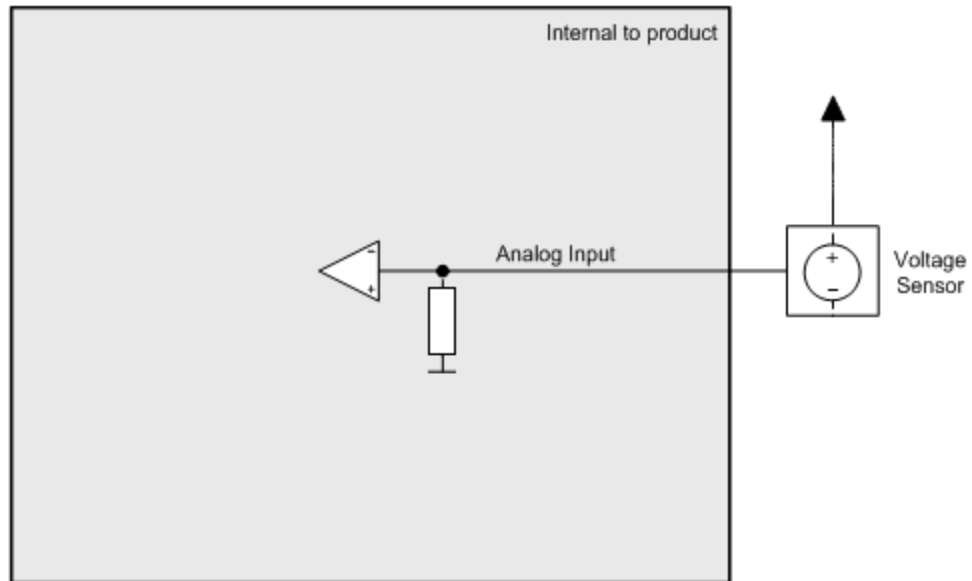

Figure 31: Voltage sensor connection

13.7.4. Potentiometer (Ratiometric) Sensors

Potentiometers and other ratiometric type sensors can be wired directly to analog inputs.

Potentiometers are resistive devices that use a wiper arm to create a voltage divider. Changes to resistive measurements happen as the wiper arm moves along a resistive element.

When connecting potentiometer sensors, it is important to do the following:

- Connect one end of the sensor to the `SENSOR_SUPPLY` pin, and the other end to a `SENSOR_GND` pin on the CM0711.
- Connect the sensor signal to an analog input.

The following shows a typical potentiometer sensor connection:

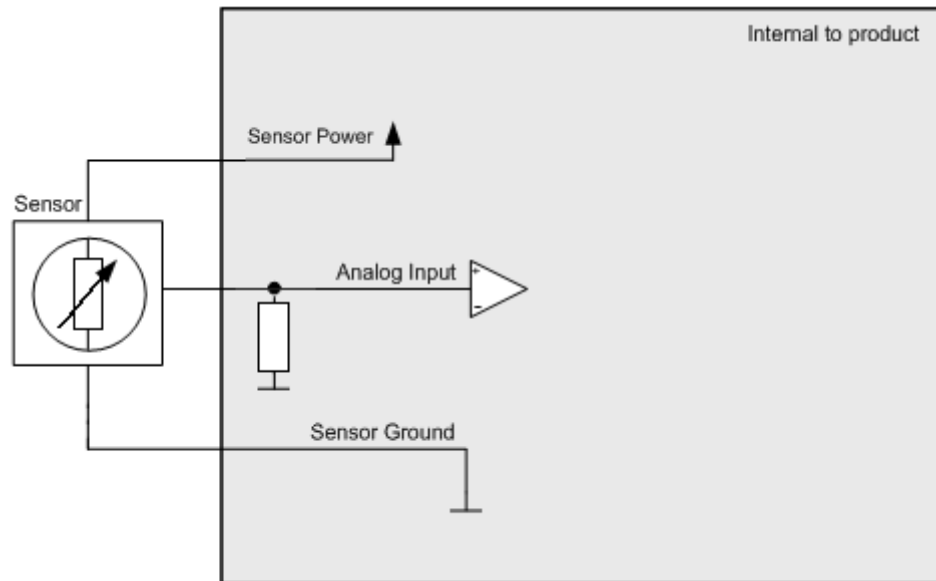

Figure 32: Potentiometer (ratiometric) sensor connection

14. Start-Up

14.1. Start-Up Procedures

This chapter contains instructions for action to be taken in connection with the initial start.



WARNING

Risk of injury!

If the control system is not fitted properly, the machine could move uncontrollably. The machine's engine shall not be started before the control system is completely fitted and its signals are verified.

14.1.1. Starting the Control System

Start the control system as follows:

- Prior to start, all modules and cables are to be fitted correctly.
- Check fuses, i.e. make sure that the supply voltage to the modules is equipped with the correct fuse.
- Make sure that connections for supply voltage and return lines are correct in the cable's conductor joint.
- Make sure the emergency stop works.
 - The emergency stop should disconnect the supply voltage to all modules.

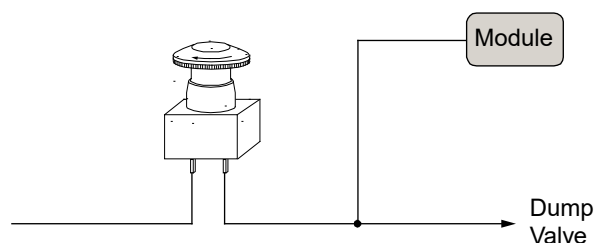

Figure 33: Emergency stop

Alternatively, the emergency stop may also shut off the diesel engine or a dump valve, and with that depressurize the hydraulic system.

14.1.2. Prepare for System Start



WARNING

Make sure no one is in dangerous proximity to the vehicle to avoid injuries when it starts.

Prepare for the initial system start as follows:

- The engine for the hydraulic system's pump shall be in off position.

- Make sure that all connectors are properly connected.
- Turn on the control system.
- Make sure that voltage is being supplied to all modules; the power-on LED's shall be illuminated on all modules. Also make sure that master is in contact with all modules.
- Make sure the emergency stop is functioning properly.

14.1.3. Start the System

Start the system as follows:

- Start the engine for the hydraulic system's pump, assuming that the above mentioned inspections have been carried out and shown correct values.
- Calibrate and adjust input and output signals according to the instructions and check each and every output function carefully.
- In addition to these measures, the machine shall also meet the machine directives for the country in question.

15. Summary of Tests

15.1. Design Verification Tests

The following table lists the design verification tests that were performed for the CM0711.

Table 23: Design Verification Test Summary

Ref #	Test Specification	Test Description	Test Level
1.	EN 60068-2-2 B	Hot Soak	+85°C, 96h
2.	EN 60068-2-1 A	Cold Soak	-40°C, 96h
3.	EN 60068-2-14 Nb	Thermal Cycling	-40...+85°C, 2cycles
4.	EN 60068-2-14 Na	Thermal Shock	-40...+85°C, 10cycles
5.	EN 60068-2-27	Mechanical Shock	50g, 6ms, 18shocks
6.	EN 60068-2-29	Bump	40g, 6ms, 600bumps
7.	EN 60068-2-32 Ed	Drop Test	1000mm, 6drops
8.	EN 60068-2-6 section 8.2	Sine Sweep Vibration	9...500Hz, 5g, 6h
9.	EN 60068-2-64 Fh	Random Vibration	10...350Hz
10.	EN 60068-2-6 section 8.1	Resonance Search Vibration	10...2000Hz, 5g, 5min
11.	EN 60068-2-13 M	Altitude Test, Transport	13600m, 30min
12.	EN 60068-2-13 M	Altitude Test, Operational	4850m, 60min
13.	SAE J1211	Particle Impact	
14.	EN 60068-2-78 Cab	Humidity Soak	30°C, 93%, 10days
15.	EN 60068-2-30 Db	Humidity Cycling	25/40°C, >90%, 6days
16.	SAE J1455	Steady State Operating Voltage	6,5...32V
17.	SAE J1455	Steady State Over Voltage	36V
18.	SAE J1455	Steady State Reverse Voltage	-36V with fuse
19.	SAE J1455	Steady State Short Circuit	0/32V, 5min
20.	SAE J1455	Steady State Power Up	0...9V
21.	EN 60068-2-52 Kb	Salt Spray	35°C, severity 4, 14days
22.	EN 60068-2-74	Chemical Resistance	Diesel fuel, oils, fertilizers, calcium chloride, calcium hydroxide, ammonia
23.	EN 60259	Dust Ingress IP6X	
24.	DIN 40050-9	Water Ingress IPX9K	+85°C, 30sec

Ref #	Test Specification	Test Description	Test Level
25.	ISO 7637-2 5.6.1	Transient 1	Level 3, 12 and 24V systems
26.	ISO 7637-2 5.6.2	Transient 2a	Level 3, 12 and 24V systems
27.	ISO 7637-2 5.6.2	Transient 2b	Level 3, 12 and 24V systems
28.	ISO 7637-2 5.6.3	Transient 3a	Level 3, 12 and 24V systems
29.	ISO 7637-2 5.6.3	Transient 3b	Level 3, 12 and 24V systems
30.	ISO 7637-2 5.6.4	Transient 4	Level 3, 12 and 24V systems
31.	ISO 7637-2 5.6.5	Transient 5	Level 3, 12 and 24V systems
32.	ISO 10605	ESD Operating	8kV contact, 15kV air
33.	ISO 7637-2 4.3	EMC – Conducted Transient Emissions	12V and 24V systems
34.	EN 55025	EMC – Conducted RF Emissions	0,15...108MHz class3
35.	ISO 11452-4	EMC – Conducted Susceptibility	1...200MHz, 100mA
36.	ISO 11452-2	EMC – Radiated Susceptibility	200...1000MHz, 100V/m
37.	ISO 13766	EMC – Radiated Emissions	30...1000MHz

16. Glossary of Terms

A

AC-coupled

A circuit that eliminates the DC offset voltage of the signal. This circuit is typically used with frequency inputs that have a DC offset. Note that the DC offset value varies by product.

active-high

Input type that is considered "on" when it reads a battery voltage level and "off" when it is floating or grounded.

active-low

Input type that is considered "on" when it reads a ground voltage level and "off" when it is floating or connected to battery voltage.

aliasing

A situation can arise in digital systems where a sampled analog value produces a measured signal with a frequency that is less than the actual analog signal. Aliasing occurs when the analog signal being sampled has a frequency greater than half the sample rate.

amplified

A circuit that applies a gain with a value greater than one (1) to a measured signal, which is typically used with analog inputs.

analog input

An input that allows a voltage level to be read and converted to discrete digital values within a microprocessor.

anti-alias filtering

Filters incorporated in hardware that ensure the analog value being read by the module does not have a frequency component greater than half the sample rate.

application software

A level of software that makes a product (hardware) perform desired functions for the end user.

attenuation

Decreasing the voltage level of an input signal to maximize the resolution of an input.

C

CAN

Controller Area Network

CAN High

One of the wires used in the shielded twisted-pair cable, which provides the positive signal that, when connected with CAN Low, provides a complete CAN differential signal.

CAN Low

One of the wires used in the shielded twisted-pair cable, which provides the negative signal that, when connected with CAN High, provides a complete CAN differential signal.

CAN Shield

A shielding that wraps around the CAN High and CAN Low wires (twisted-pair), completing the shielded twisted-pair cable.

CMOS

CMOS stands for Complimentary Metal-Oxide Semi-Conductor

Controller Area Network

A computer network protocol designed for the heavy equipment and automotive environment that allows microcontrollers and other devices to communicate with each other without using a host computer; also known as CAN.

controller I/O board

A development product that allows users to test products on a bench in a development environment before installing the product on a vehicle.

controller module

Any module that has embedded software used for controlling input and output functions.

current feedback

A circuit that allows software to measure the amount of current provided by the outputs. This circuit is typically connected to an analog input that is connected to the microprocessor. Note that current feedback is also known as current sense or current sensing.

current feedback control

Varying the duty cycle of an output so the output provides a desired amount of current to the load.

current sensing

When an analog input reads the amount of current flowing through an output driver circuit.

D**Data Link Adaptor (DLA)**

A development tool that connects the CAN bus to a personal computer (through a USB or RS232 port), so that programming and diagnostics can be performed on the product before installing it in a vehicle.

DC-coupled

A circuit used with signals that have minimal DC offset. The signal being read by this circuit must fall within the detection threshold range specified for the input.

de-rating

To reduce the rated output current level to a value less than the specified rating. De-rating is typically done so a product does not over-heat.

digital input

An input that is typically controlled by an external switch that makes the input either active (on), or inactive (off).

driver (hardware)

An electronic device that switches power or ground to an external load. The driver is a key component used in all output circuits.

driver (software)

A block of software that provides access to different hardware components.

F**FET**

Field Effect Transistor

Field Effect Transistor (FET)

An electronic device used either as a power switch, or amplifier in electronic circuitry. FETs are typically used as drivers.

frequency input

An input that allows a frequency value to be read from an oscillating input signal.

G**gain**

Increasing the voltage level of an input signal to maximize the resolution of an input.

ground shift

The difference in ground potential from one harness location to another, which is typical in systems with large wire harnesses and high current loads.

H**H-bridge**

A combination of two half-bridge circuits used together to form one circuit. H-bridges provide current flow in both directions on a load, allowing the direction of a load to be reversed.

half-bridge

When a high side and low side switch are used together to provide a load with both a battery voltage and a ground.

high side output

An output that provides switched battery voltage to an external load.

hysteresis

Causes the activation and deactivation voltage levels on an input to overlap, which ensures the input only changes state when there is a significant shift in voltage.

I**ID-Tag**

The module can be configured by using an ID-Tag, which is connected between the module's address high and low pins. The ID-Tag will enable a numeric input to the application.

inductive load

A load that produces a magnetic field when energized. Inductors are electrical components that store energy and are characterized by the following equation:

$$E_{\text{stored}} = \frac{1}{2}LI^2$$

L**LED**

Light Emitting Diode

load

Any component that draws current from the module, and is typically switched "on" and "off" with outputs. Examples include bulbs, solenoids, motors, etc.

logic power

Power pins for the microprocessor and logic peripherals.

low side output

An output that provides a switched ground voltage to an external load.

N**Nyquist criterion**

The Nyquist criterion states that to avoid aliasing, ensure your analog input sample rate is greater than twice the frequency of your analog signal.

O**open load**

A fault state that occurs when a load that should be connected to an output becomes disconnected, which typically occurs because of a broken/worn wire in the wire harness or a broken/worn connector pin.

over-current

A fault state that occurs when a load draws more current than specified for an output, which results in the output shutting down to protect the circuitry of the product.

over-voltage

When the voltage exceeds the normal operating voltage of the product, which results in the CM0711 shutting down to protect its circuitry.

P**power control input**

A digital input that is used to turn on the product. When the input is active, the product "turns on" and operates in normal mode, and when the input is inactive, the product "powers down" and will not operate.

procurement drawing

A mechanical drawing showing the dimensions, pin-outs, and implemented configuration options for a Parker product.

Proportional Integral Differential (PID)

This refers to the proportional-integral-differential closed-loop control algorithm.

pull-down

A resistor that connects an input to a ground reference so that an open circuit can be recognized by the microprocessor, which is typically used on active-high digital inputs or analog inputs.

pull-up

A resistor that connects an input to a voltage reference so that an open circuit can be recognized by the microprocessor, which is typically used on active-low digital inputs or analog inputs.

Pulse Width Modulation (PWM)

A type of square wave frequency signal where the ratio of “on” time vs. “off” time is determined by the duty cycle of the signal. The duty cycle refers to the percent of time the square wave is “on” vs. “off”. PWM signals are typically used to drive varying amounts of current to loads, or to transmit data.

S**sensor power**

A regulated voltage output that provides a set voltage level for analog sensors attached to the product.

shielded twisted-pair cable

A type of cable used for CAN communication that consists of two wires (CAN High and CAN Low) twisted together. These wires are covered by a shield material (CAN Shield) that improves the cable's immunity against electrical noise.

short-to-battery

A fault state that occurs when an input or output pin on the product is connected to battery power, potentially resulting in high current flow.

short-to-ground

A fault state that occurs when an input or output pin on the product is connected to system ground, potentially resulting in high current flow.

system noise

Electrical interference generated from external devices that affect the behaviour of inputs, outputs and sensors. System noise can be generated from things like the vehicle alternator, engine, transmission, etc.

T**trip time**

The amount of time it takes a circuit to protect itself after a fault occurs.

W**Wake on CAN**

A method of power control that makes the product turn on when a CAN message is received from another module in the system, and turn off as determined by the application software.

wetting current

The amount of current that flows into, or out of, a digital input. The current helps eliminate oxidation on the contacts of digital switches and relays. Switches with gold or silver contacts typically require much less wetting current than standard tinned contacts.

17. Index

A

A/D converter • 41

AC-coupled • 72

Active-high • 72

Active-low • 72

Aliasing • 72

Amplified • 72

Analog inputs • 19, 72

- Installation connections • 23

- Type 1 (resistive sensors) • 19

 - Capabilities • 19

 - Configuration • 20

 - Software considerations • 21

- Type 2 (general purpose) • 21

 - Capabilities • 21

 - Configuration • 22

 - Software considerations • 23

Analog to digital converter • 41

Anti-alias filtering • 72

Application examples • 58

- Connecting common sensors • 65

- Controlling a linear actuator • 27, 63

- Controlling a proportional valve • 61

- Controlling indicator lights • 59

- Controlling motor speed • 62

- Implementing safety interlocks • 58

- Using one analog input as two digital inputs • 62

Application software • 72

Attenuation • 72

C

CAN • 45, 72

- CAN High • 73
- CAN Low • 73
- CAN Shield • 73
- Capabilities
 - Analog input type 1 (resistive sensors) • 19
 - Analog input type 2 (general purpose) • 21
 - Frequency input • 25
 - High side output • 27
 - Type 1 (low current) • 28
 - Type 2 (high current) • 28
 - Ignition input • 38
 - J1939 CAN • 45
 - Low side output • 33
 - Module ID • 47
 - Module power • 37
 - Sensor power • 39
- CMOS • 73
- Communication • 45
 - CAN • 45
 - Module ID • 47
- Configuration
 - Analog input type 1 (resistive sensors) • 20
 - Analog input type 2 (general purpose) • 22
 - Frequency input • 25
 - High side output • 29
 - J1939 CAN • 45
 - Low side output • 34
 - Module ID • 48
- Connecting common sensors • 65
- Connecting the vehicle harness • 57
- Connecting to a development system • 15
- Connectors • 50
 - General • 50
 - Mating connector part numbers • 51
 - Pin-outs • 51

Controller Area Network (CAN) • 45, 73

Controller I/O board • 73

Controller module • 73

Controlling a linear actuator • 63

Controlling a proportional valve • 61

Controlling indicator lights • 59

Controlling motor speed • 62

Creating software applications • 18

Current feedback • 73

Current feedback control • 73

Current sensing • 73

D

Data Link Adaptor (DLA) • 73

- Connecting • 15

- Installing driver software • 15

DC-coupled • 74

De-rating • 74

Design verification tests • 70

Designing the vehicle harness • 57

Diagnostics

- High side outputs • 32

- Low side outputs • 36

- Module ID • 48

- Sensor power • 40

Diagram conventions • 10

Digital inputs • 74

Dimensions • 54

DLA • 73

Downloading software applications • 18

Driver (hardware) • 74

Driver (software) • 74

E

Electrical guidelines • 57

Environmental requirements • 55

F

Fault protection

- High side outputs • 32

- Low side outputs • 36

- Module ID • 48

- Sensor power • 40

FET • 74

Field Effect Transistor (FET) • 74

Flash memory • 42

Frequency inputs • 25, 74

- Capabilities • 25

- Configuration • 25

- Installation connections • 26

- Software considerations • 25

G

Gain • 74

Gathering required materials • 14

General safety regulations • 8

Ground shift • 74

H

Half-bridge • 75

Harness • 57

H-bridge • 74

High side outputs • 27, 75

- Capabilities • 27

 - Type 1 (low current) • 28

 - Type 2 (high current) • 28

- Configuration • 29

- Diagnostics and fault protection • 32

- Installation connections • 31

- Software considerations • 30

How to use this manual • 10

Hysteresis • 75

I

- I/O overview • 13
- ID-Tag • 47, 75
 - Part numbers • 49
- ID-Tag part numbers • 49
- Ignition input • 38
- Implementing safety interlocks • 58
- Inductive load • 75
- Inputs • 19
 - Analog input type 1 (resistive sensors) • 19
 - Analog inputs type 2 (general purpose) • 21
 - Frequency inputs • 25
 - Ignition input • 38
 - Module ID • 47
- Installation connections
 - Analog inputs • 23
 - Frequency inputs • 26
 - High side outputs • 31
 - Ignition input • 38
 - J1939 CAN • 45
 - Low side outputs • 35
 - Module ID • 48
 - Module power • 38
 - Sensor power • 40
- Installing into a vehicle • 54
- Installing the Data Link Adaptor (DLA) driver software • 15
- Installing the required software tools • 15
- Internal Diagnostics • 43
- Introduction • 7

J

- J1939 CAN • 45
 - Capabilities • 45
 - Configuration • 45
 - Installation connections • 45

L

- LED • 43, 75
- Load • 75
- Logic power • 75
- Low side outputs • 33, 75
 - Capabilities • 33
 - Configuration • 34
 - Diagnostics and fault protection • 36
 - Installation connections • 35
 - Software considerations • 35

M

- Mating connector part numbers • 51
 - Mechanical guidelines • 54
 - Mechanical requirements • 55
 - Memory • 41
 - Flash • 42
 - SRAM • 41
 - Microcontroller • 41
 - Module ID • 47
 - Capabilities • 47
 - Configuration • 48
 - Diagnostics and fault protection • 48
 - ID-Tag part numbers • 49
 - Installation connections • 48
 - Module power • 37
 - Capabilities • 37
 - Ignition input • 38
 - Installation connections • 38
 - Power input switch • 38
 - Mounting location • 54
 - Mounting to a vehicle • 56
- N**
- Nyquist criterion • 75

O

Open collector sensors • 65

Open load • 32, 36, 75

Outputs • 27

 High side outputs • 27

 Low side outputs • 33

Over-current • 32, 36, 76

Over-voltage • 76

P

Pin-outs • 51

Potentiometer (ratiometric) sensors • 67

Power • 37

 Module power • 37

 Sensor power • 39

Power control input • 76

Power input switch • 38

Powering up the development system • 17

Precautions • 8

Procurement drawing • 76

Product description • 12

Proportional Integral Differential (PID) • 76

Pull-down • 76

Pull-up • 76

Pulse Width Modulation (PWM) • 76

Q

Quick start • 14

R

Reset sources • 43

S

Safety regulations • 8

Safety symbols • 7

Sensor power • 39, 76

 Capabilities • 39

Diagnostics and fault protection • 40

Installation connections • 40

Shielded twisted-pair cable • 76

Short-circuit • 32, 36

Short-to-battery • 33, 77

Short-to-ground • 36, 77

Software considerations

 Analog input type 1 (resistive sensors) • 21

 Analog input type 2 (general purpose) • 23

 Frequency input) • 25

 High side output • 30

 Low side output • 35

SRAM • 41

Start-up • 68

Summary of tests • 70

Switch sensors • 66

System noise • 77

T

Temperature monitoring • 43

Trip time • 77

U

Using one analog input as two digital inputs • 62

V

Voltage monitoring • 43

Voltage sensors • 66

W

Wake on CAN • 77

Wetting current • 77